

Programmable Operator Interface

MONITOUCH

Safety Considerations

- For safe operation, read the instruction manual or user manual that comes with the product carefully or consult the distributor from which you purchased the product, before using the product.
- Products introduced in this catalog have not been designed or manufactured for such applications in a system or equipment that will affect human bodies or lives.
- Customers, who want to use the products introduced in this catalog for special systems or devices such as for atomic-energy control, aerospace use, medical use, passenger vehicle, and traffic control, are requested to consult the Hakko Overseas Sales Section.
- Customers are requested to prepare safety measures when they apply the products introduced in this catalog to such systems or facilities that will affect human lives or cause severe damage to property if the products become faulty.
- For safe operation, wiring should be conducted only by qualified engineers who have sufficient technical knowledge about electrical work or wiring.

Notes to consider before purchasing

- Appearance and specifications are subject to modification without prior notice due to technical improvements.
- Colors in the catalog may differ from the actual colors due to printing inaccuracies.
- Consult your distributor or us for further information about products in this catalog.

www.monitouch.com

Hakko Electronics Co., Ltd.

Overseas Sales Department
890-1 Kamikashiwano-machi,
Hakusan, Ishikawa 924-0035, Japan

- Tel
+81-76-274-2144
- Fax
+81-76-274-5136
- E-mail
sales@hakko-elec.co.jp

Distributor

* Product specifications and design are subject to modification.
* Combined images are used for the screen images.
* Product colors may differ from colors in brochure photos due to printing.
* Windows and Excel are trademarks of Microsoft (USA) in the U.S. and other countries.
* Other company and product names in this brochure are registered trademarks.
* Printed with environment-friendly soy ink.



V9 series
V9 makes automation complete.

Hakko Electronics Co., Ltd.

The new MONITOUCH series scales new heights of excellence; optimum operability, intuitive controls, and extended capability to display and utilize your application.

On its release in 1988 as the first ever programmable display*, MONITOUCH augured in a new era of human-machine interface technology. It is now used as an information terminal for countless different purposes in production sites all over the world. The total number of shipments has reached around one million. Now, Hakko Electronics Co., Ltd. has introduced its new range with an impressive array of exciting new cutting-edge features expressly designed to meet the needs of our clients.

The MONITOUCH PREMIUM series, the next generation of programmable displays, is here.

*According to our own research.



V9 Standard
High performance model

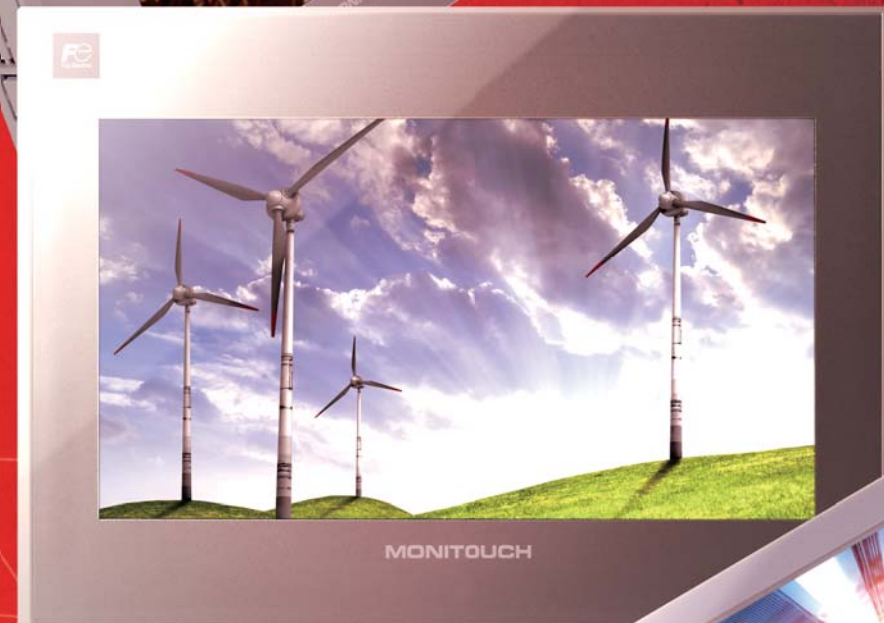

V9 Advanced
High resolution widescreen LCD with wireless LAN



V9 Lite
Basic model

MONITOUCH V9 series

04..... V9: Lineup	18..... V9: Specifications	28..... V8: Dimensions & Parts Names
06..... V9: Features 1	20..... V9: System Configuration	29..... V8: Accessories
08..... V9: Features 2	22..... V9: Dimensions & Part Names	30..... PLC Connection - Summary
10..... V9: Extended Functions 1	24..... V9: Product Details	32..... Temperature Controller / Servo / Inverter Connection - Summary
12..... V9: Extended Functions 2	25..... V9: Accessories	34..... Service & Support
14..... V-SFT Ver.6	26..... V8: Lineup	35..... Product Warranty
17..... V9: Optional Units	27..... V8: Specifications	

We provide a wide range of display, with wide
The V9 series lineup helps to establish the most
fulfilling the needs of automation.

range of functionalities.
efficient information system

V9 Advanced

V9 Standard

V9 Lite

10.1 inches

- V9101iWRLD DC
- V9101iWLD DC

7 inches

- V9071iWRLD DC
- V9071iWLD DC

15 inches

- V9150iX AC
- V9150iXD DC

12.1 inches

- V9120iS AC
- V9120iSD DC

10.4 inches

- V9100iS AC
- V9100iSD DC

8.4 inches

- V9080iSD DC

10.4 inches

- V9100iC AC
- V9100iCD DC

8.4 inches

- V9080iCD DC

5.7 inches

- V9060iTD DC



Model	V9101iW	V9071iW	V9150iX	V9120iS
Display size	10.1" wide	7" wide	15"	12.1"
Display device	TFT color LCD	TFT color LCD	TFT color LCD	TFT color LCD
Resolution W:H (dots)	1024×600	800×480	1024×768	800×600
Colors	16.7 million ^{*1}	16.7 million ^{*1}	16.7 million ^{*1}	16.7 million ^{*1}
Touch switch	Capacitance	Capacitance	Analog resistance film	Analog resistance film
Screen memory (FROM)	64MB	64MB	64MB	64MB
Backup memory (SRAM)	800KB	800KB	800KB	800KB
Ethernet (LAN)	○	○	○	○
Extended cable LAN	○	○	△ ^{*2}	△ ^{*2}
Wireless LAN	△ ^{*2}	△ ^{*2}	△ ^{*2}	△ ^{*2}
Serial (CN1)	RS-232C/422/485	RS-232C/422/485 ^{*3}	RS-232C/422/485	RS-232C/422/485
Serial (MJ1)	RS-232C/485	RS-232C/485	RS-232C/485	RS-232C/485
Serial (MJ2)	RS-232C/485	RS-232C/422/485	RS-232C/485	RS-232C/485
Communication I/F	○	○	○	○
Optional unit I/F (GUR-XX)	○	—	○	○
SD card I/F	○	○	○	○
USB (Type A)	○	○	○	○
USB (Type mini-B)	○	○	○	○
Sound output	○	—	○	○

Please refer to page 24 for the details of each model.

V9100iS	V9080iSD	V9100iC	V9080iCD	V9060iTD
10.4"	8.4"	10.4"	8.4"	5.7"
TFT color LCD	TFT color LCD	TFT color LCD	TFT color LCD	TFT color LCD
800×600	800×600	640×480	640×480	640×480
16.7 million ^{*1}	16.7 million ^{*1}	16.7 million ^{*1}	16.7 million ^{*1}	260 thousand ^{*1}
Analog resistance film	Analog resistance film	Analog resistance film	Analog resistance film	Analog resistance film
64MB	64MB	64MB	64MB	64MB
800KB	800KB	800KB	800KB	800KB
○	○	○	○	○
△ ^{*2}	△ ^{*2}	—	—	—
△ ^{*2}	△ ^{*2}	—	—	—
RS-232C/422/485	RS-232C/422/485	RS-232C/422/485	RS-232C/422/485	RS-232C/422/485 ^{*3}
RS-232C/485	RS-232C/485	RS-232C/485	RS-232C/485	RS-232C/485
RS-232C/485	RS-232C/485	RS-232C/485	RS-232C/485	RS-232C/422/485
○	○	○	○	○
○	○	—	—	—
○	○	○	○	○
○	○	○	○	○
○	○	—	—	—

*1: Only for pictures, 3D parts and videos. Other items are displayed in 65,536 colors. *2: Depending on the model. *3: When optional unit DUR-00 is installed.

Kindness to our customers is the origin of

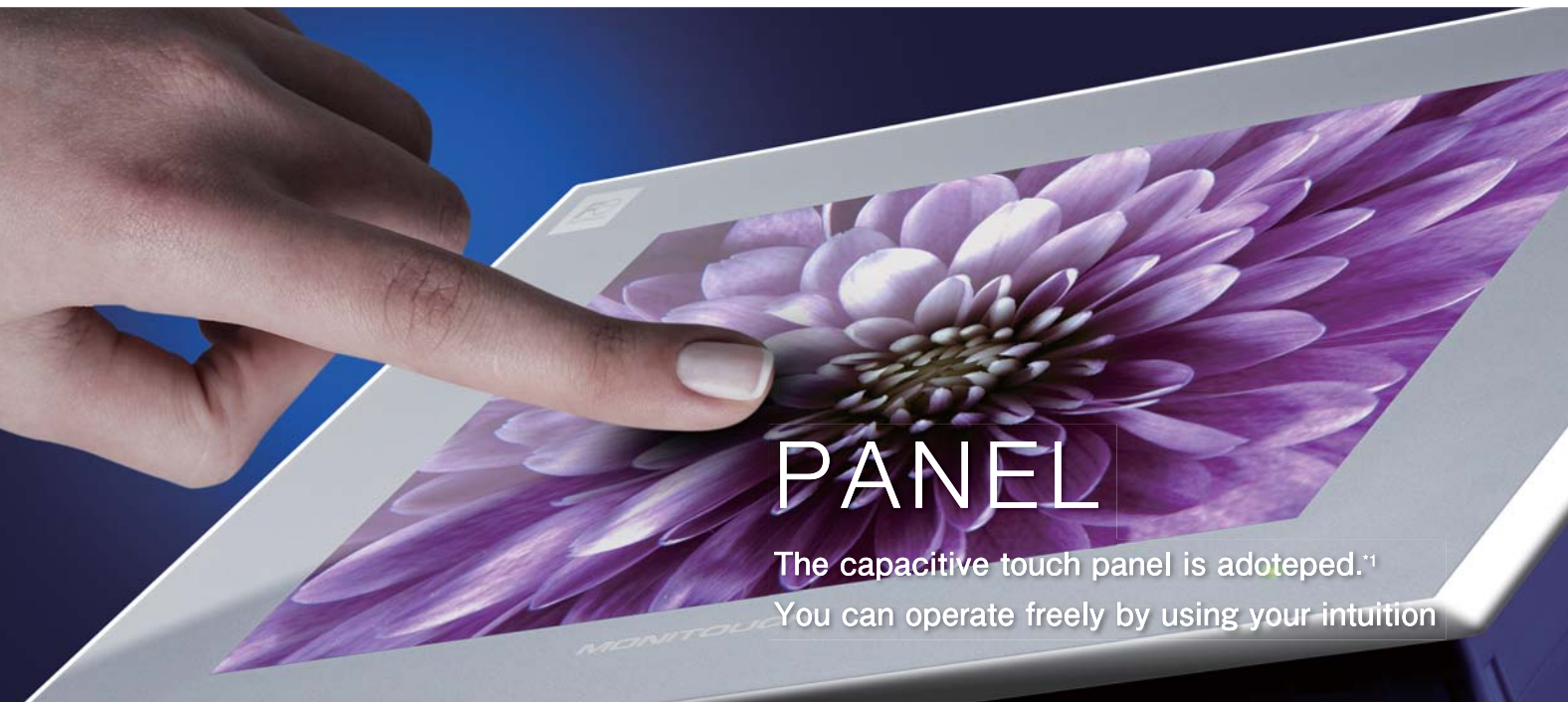

PANEL
The capacitive touch panel is adopted.^{*1}
You can operate freely by using your intuition

*1: Only V9 Advanced model.

Smooth Operation with Your Fingers

Zooming In and Out with Two Fingers V9 Advanced

The displayed image can be magnified up to 200% by pinching out the screen^{*2}, and reduced to the original size by pinching it in.

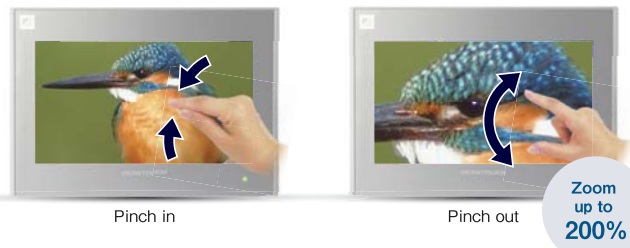

*2: The image can be scaled up and down by double tapping for V9 Standard/Lite.

Scrolling Magnified Images

You can view a particular part of a magnified image in close-up while scrolling around the screen.



Abundant Quantity of Information

Displaying Four Times the Screen Size First in industry

Twice in width

Twice in height

The whole area of a large image can be confirmed easily by scrolling the screen without the need of switching it. The navigation window helps you to recognize the current displayed position instantly.

Information Max. 4 times

4 times in width

4 times in height

*3: According to our own research.

Widescreen LCD V9 Advanced

V9 Advanced models are equipped with a high-precision, high-resolution widescreen (16:9). Greater volume and variety of information can be displayed on the screen.

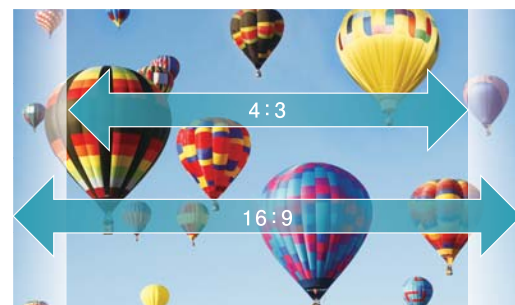

evolution of MONITOUCH.

Enhanced Display Capacity

Video Player Function

A video player function is provided with all models of the V9 series. The video player can be operated by a switch on the V9 or a command from the system menu or PLC. Animated images used for operation instruction and other operations will reduce the down time of machines and facilitate the standardization of operation.



*4: Please see the specifications (P18) for models with sound output function.

PDF Viewer Function

PDF files stored on SD cards can be displayed. PDF instruction manuals can be used for troubleshooting.

Convenient

Fast navigation to the desired page, using bookmarks.

Versatile Screen Transition Functions

15 kinds^{*6} of functions are available for screen switching and overlapping.

E.g.) Slide-in

15 kinds of screen change

*6: Four types for overlapping windows.

7-segment Fonts for Realistic Expression

7-segment fonts allow for realistic, highly visible expression of measuring instruments.

Non-illuminated segments can be shown in a subtle color.

Video/RGB Input-Output Support

By attaching an optional unit, videos and RGB images can be displayed on the V9. Also, images displayed on the V9 can be sent to external displays.

Supports 16.7 million colors

Model	Item
GUR-04	Video IN : 1CH
GUR-01	RGB IN : 1CH
GUR-02	RGB OUT : 1CH

Optional unit *5: The GUR-01 supports 65,536 colors.

Compatible with Vertical Placement

The screen can also be displayed and edited while the panel is placed vertically (by left or right turning).

E.g.)

Main Menu Screen can also be displayed vertically.

For all models

COLOR

Displays 16.7 million colors^{*7} for delicate expression of gradation

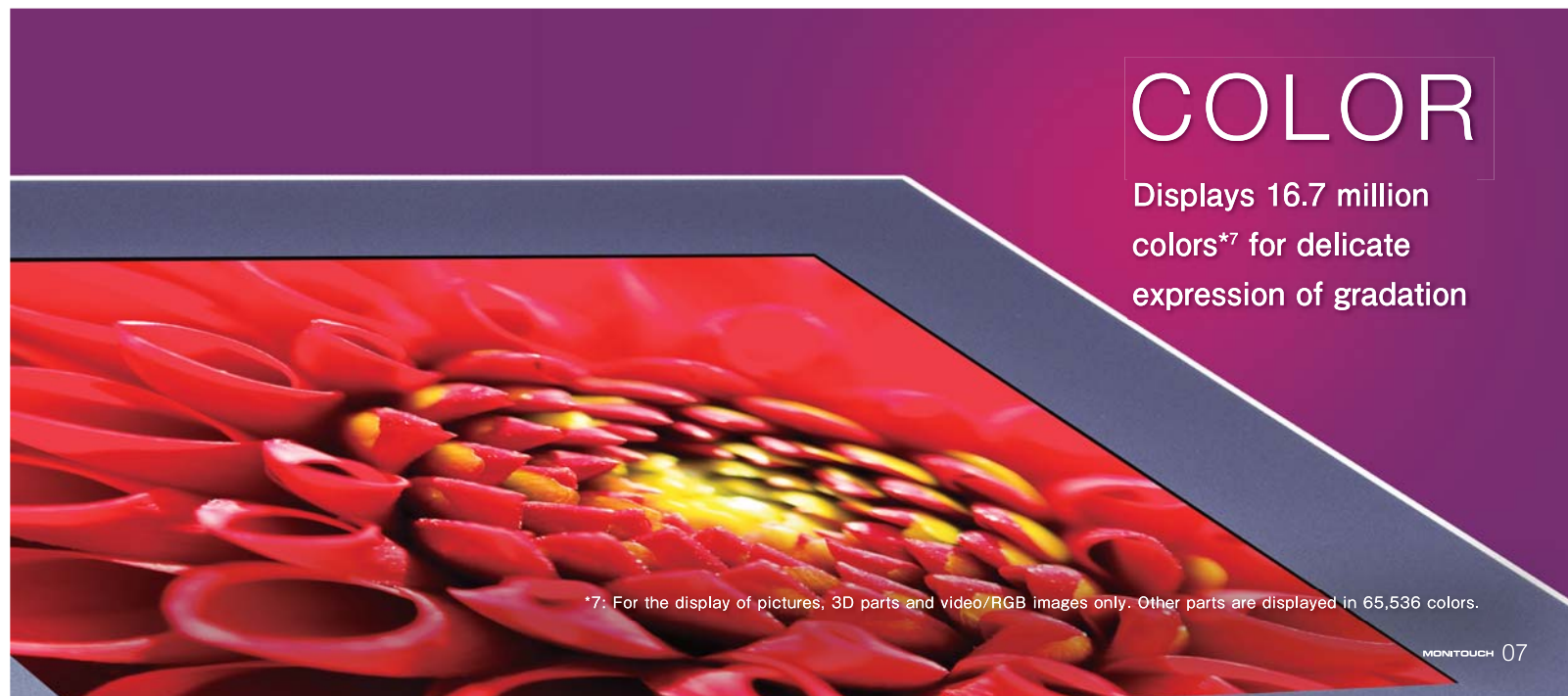

*7: For the display of pictures, 3D parts and video/RGB images only. Other parts are displayed in 65,536 colors.

Easy and safe network monitoring and control



VNC Server Function

Remote Connection from Tablet PCs

All types of the V9 series are equipped with VNC server function for remote monitoring and control of production from your tablet PC.



Wireless LAN Function

Wireless Data Transfer

By connecting a PC to a V9 via wireless LAN, transmission of screen program and the reading and writing of files through FTP server/client function becomes available. On-site debugging can be conducted easily, without the need for a cable connection.



Data Transfer via V9 Panels

With macro EREAD/EWRITE, data can be transferred between machines using V9 panels as a gateway.

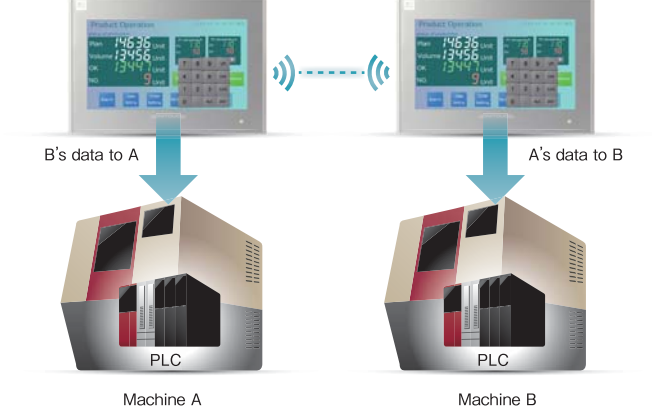

Networking

Secure, easy and low cost remote control by VPN

MONITOUCH, equipped with VPN (Virtual Private Network) function, facilitates secure remote control through a public network. In addition, VPN's routing function enables a V9 series unit to connect with PLC and network cameras via Ethernet.

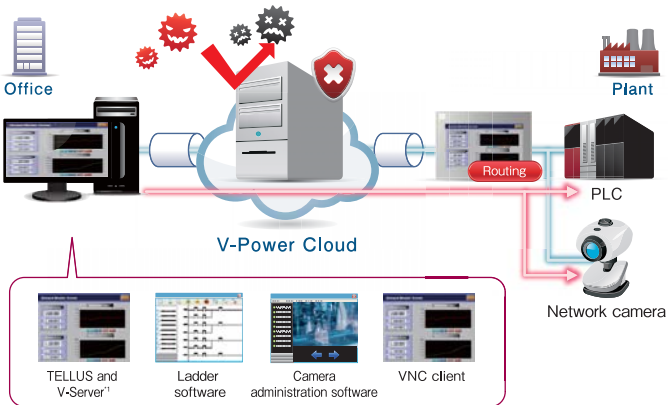

*1 TELLUS and V-Server for V9 is under development.

E-mail Transmission Function

E-mails can be sent to preset addresses when alarms are issued or lifted. Addresses can be set for each type of alarm.



Secure Enhanced Security
SSL/TLS transmission is supported, so you can work with peace of mind.

Ladder Program Transmission (3-way) Support

Up to 3 PLCs are accessible to monitor and revise PLC programs by connecting a PC to V9 via Ethernet.

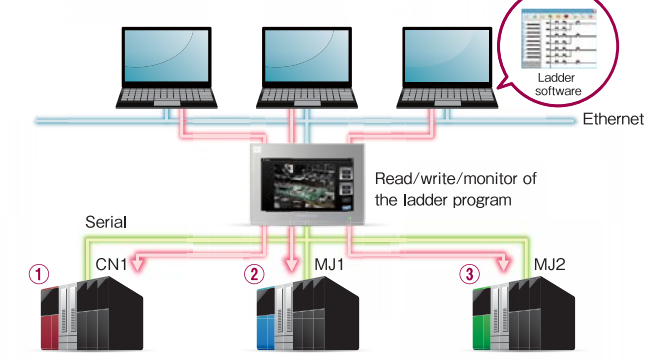

FTP Server/Client Support

FTP Server Function

Files in a storage media inserted in a V9 can be read out and written using a PC.

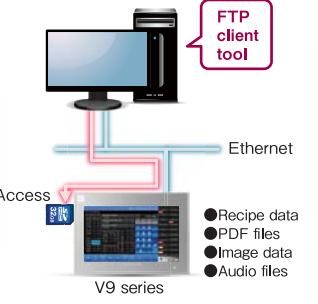

FTP Client Function

Files on an FTP server can be read and written using a V9. It is also possible to use a V9 as an FTP server and access its stored data.

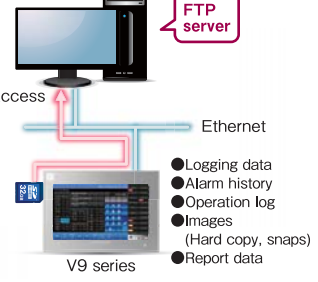

- Recipe data
- PDF files
- Image data
- Audio files
- Logging data
- Alarm history
- Operation log
- Images (Hard copy, snaps)
- Report data



Easy verification of daily data and error reports



LOGGING

Improved functions for displaying trend data and alarms

Screen Overlapping

Improved Overlapping Functions

Up to 10 windows can be overlapped on the screen. No limit on the size of each window.

You can make all ten windows transparent at the same time.

All of the ten windows can be left displayed even when the screen is changed.



10 windows at once

Select items to display constantly.

Trend Data Display

Backup Data Display

Backup files can be loaded and displayed on V9. Alarm backup data can also be displayed.

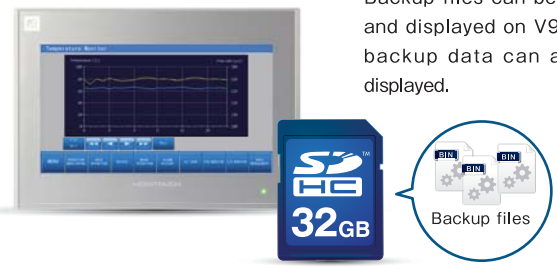

Coordination with the Scheduler

Operations such as bit output and execution of macro programs can be scheduled on a specific date and time. Also, start and stop of logging, and data saving can be conducted by setting the logging conditions.

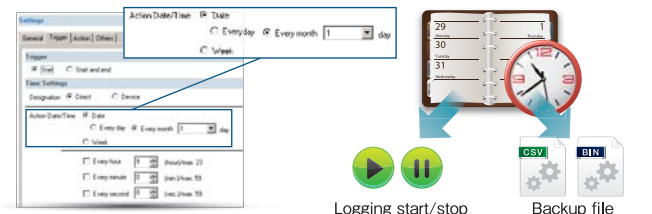

Easy Creation of Backup Files

By using the scheduler, backup files are automatically created at scheduled timings.

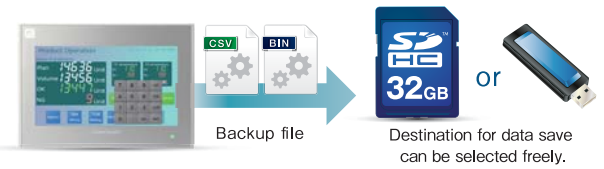

Magnification of Trend Graph Scale

The time scale of trend graph can be magnified, and the display can be scrolled by touch and drag.

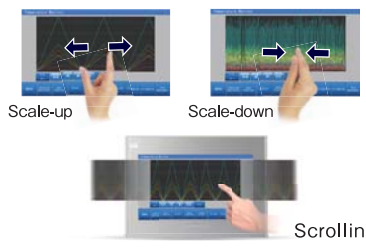

Alarm Display

Scrolling of the Alarm Messages

The entire alarm message can be displayed by scrolling the screen with touch and drag.



Scrolling the alarm messages

Running Emergency Messages

Alarm messages run automatically at a specified position when alarms are occurred.



Four-times of Normal Overlapping Windows

Four times more information than of normal overlapping windows can be registered and used as sub screen.



Various Screen Transition Functions

Four kinds of functions such as slide-in and fade-out are available for screen switching and overlapping.



OVERLAP

Exponentially improved display performance by extended functions



Easy and smooth operation with new functions



SETTING

Various setting functions for improving usability

Unit Display

Display of V9 Status

The status of V9 is displayed in the status bar.^{*1}

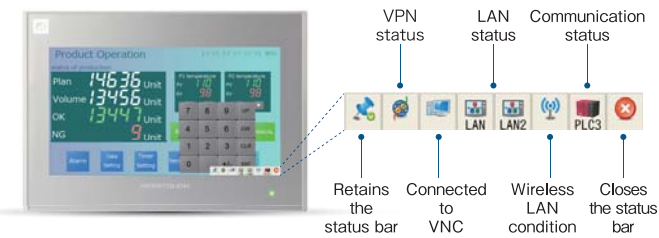

*1: The contents of the status indication are subject to change.

System Keyboard Available

A versatile keyboard for inputting upper and lower case letters and numbers is available for easy setting. Select the system keyboard from the set menu.



Local Screen Settings

Transmission Settings

Transmission settings with connected devices can be modified on the V9.

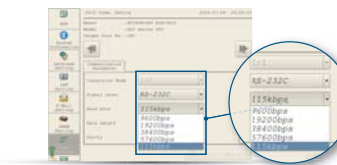

Communication setting

Backlight Settings

Backlight settings can be modified on the V9.

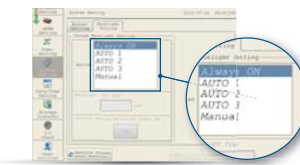

Backlight setting

Buzzer Settings

Buzzers settings can be modified on the V9.

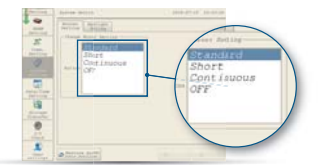

Buzzer setting

Operation Log

Improved Operation Log Viewer

The operability and visibility of the log viewer have been improved.



Search Function

Operation log can be searched for by specifying an operator or date and time.

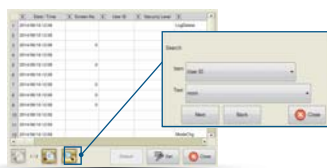

Filter/Sort Settings

Filter and sort can be set for displayed items.



Display Item Settings

It is possible to select items to display in the operation log.

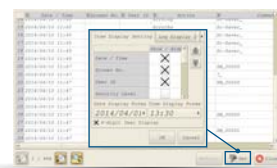

Recipe

Global Control Function

It is possible to read and write to specified files and record data, regardless of the screen displayed, by turning on or off a bit.

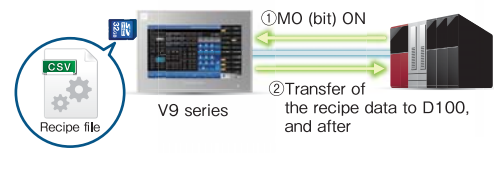

Transferring recipe data to the PLC

D100	150
D101	30
D102	10
D119	5

Filter Settings

The required data can be easily extracted using the recipe selection list dialog to narrow down file and record searches.

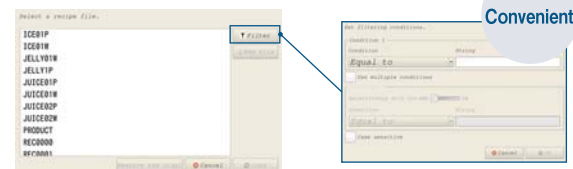

Network Query

Ethernet network status and IP redundancy within the network can be verified.



Network Test

E-mail Settings

E-mail addresses and SMTP IP addresses can be modified.

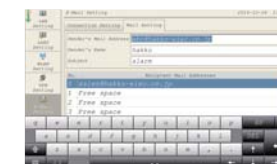

E-mail Setting

User Settings

User data can be edited, added and deleted, and user permissions such as the security level can be modified.

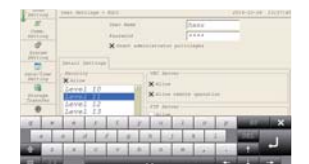

User Setting



Simple configuration of beautiful screens

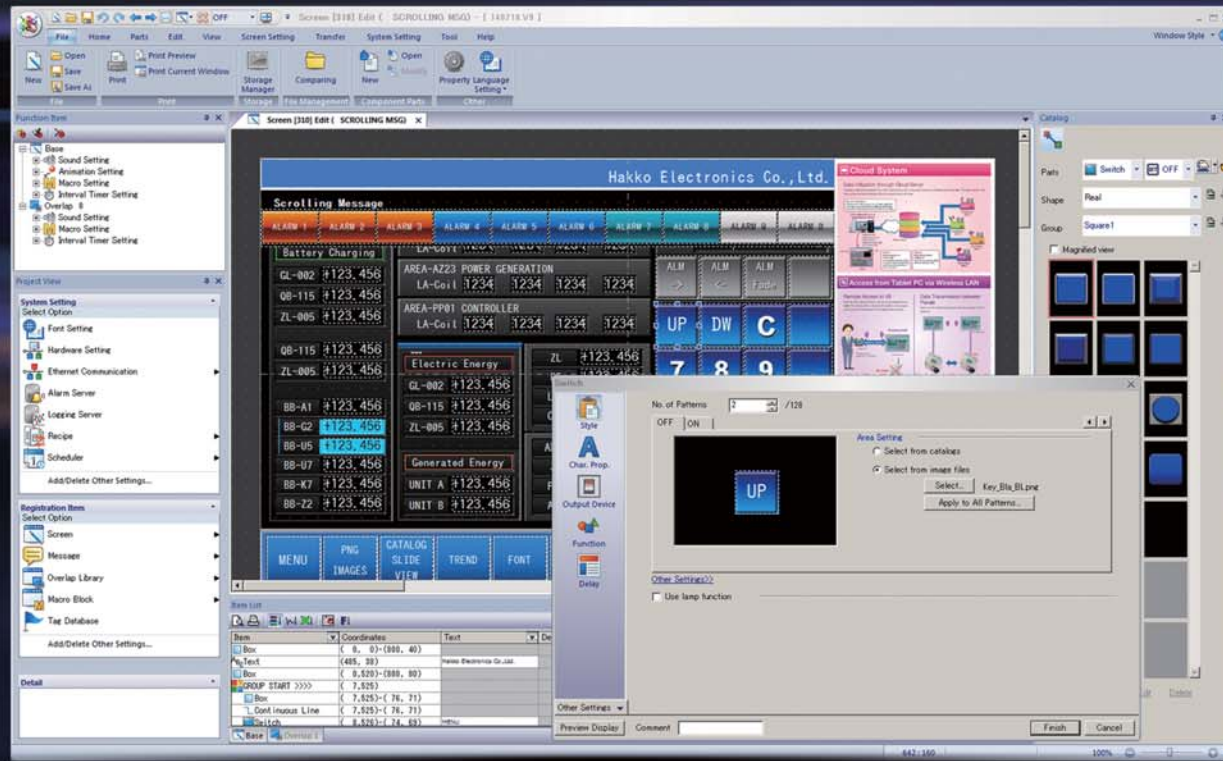

V-SFT ver.6

PC	PC/AT compatible machine with Windows
OS	Windows XP/ XP 64Edition/ Vista 32bit/ Vista 64bit/ Win 7 32bit/ Win 7 64bit/ Win 8 32bit/ Win 8 64bit/ Win 8.1 32bit/ Win 8.1 64bit
CPU	Pentium 4 2.0GHz or higher recommended.
Memory	2.0GB or more
Hard disk	For installation: 2.0GB or more available space

* For installing the OS, administrator authority is required.

Disc drive	DVD-ROM drive
Display	Resolution: 1024×768 (XGA) or more
Color indication	High color (16 bit) or higher
Others	Microsoft .NET Framework 4.0 or 4.5 is required. (When .NET Framework 4.0 or 4.5 has not been installed in PC, Framework 4.0 is installed automatically.)

Compatibility with Previous Models

V8 series Compatibility

V-SFT Ver. 6 provides intuitive operation, with easy-to-use visual tools and refined displays. In addition to the V9 series, V-SFT Ver. 6 is also compatible with the V8 series.

Compatible with Data from Former Models

Screen data produced using previous versions of V-SFT can be converted for use in the current model. It is possible to use former screen data assets.

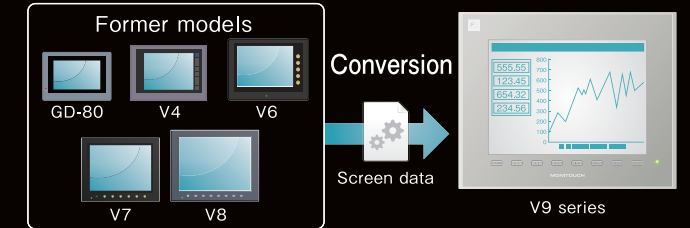

Configuration of Easy-to-view Screens

Wider Range of Parts

The number of picture icons has been increased, and the icons with plain design have been added. Pick from the wide range of ready-made icons for sophisticated representation.



Simple icons added

Popular simple icons that are used widely on smartphones have been introduced.



Increased picture icons

The number of the picture icons has been increased.



Improved 3D Parts Scaling Function

3D parts can be scaled up and down without changing the widths of frames. Frame size can be modified by batch, or individually according to the item type.

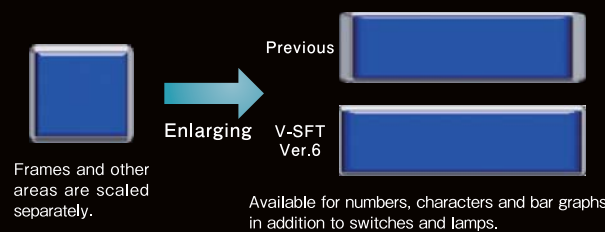

* For V9 series square picture icons and 3D parts with frames (excluding some icons and parts)

Line Width Setting

The line widths of graphic items and trend items (graph lines, reference lines) can now be set in eight steps. Effective screens can be created using a variety of drawing tools and graph representations.



* Excluding thick lines

Copy/Paste of Microsoft Office Data

Graphics created in Microsoft Office Word, Excel and PowerPoint can be copied and pasted into V-SFT files by converting them to pictures, patterns or parts.

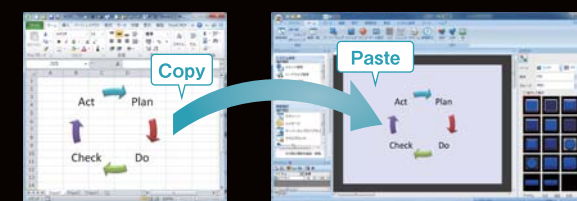

Pasting of an Image File

It is possible to paste a PNG file directly onto the screen. JPG, BMP and GIF formats are also supported as image files, allowing you to create whatever visually impressive screen you choose.

Upgraded Operability

Ribbon Menu

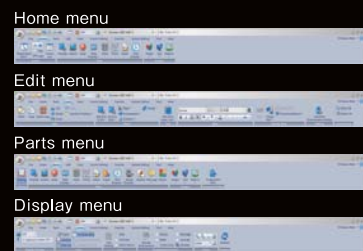

The ribbon-shaped menu bar is available. Enlarged icons are easily visible also improves the operability remarkably.

Graphic Indication of System Configuration



The improved hardware setting screen makes it easy to grasp exactly how devices are connected together in the system.

Docking Windows



The project view windows and item view windows can be docked or floated easily.

Integration of Search Menu



The search menu, which used to be displayed separately, has now been integrated for easy operation.

Enhanced Interlocking Setting



Interlock can be set with a ladder drawing screen. Multiple conditions for interlocking can be easily set. It is possible to set interlocking for keypad indication conditions in addition to switch conditions. Up to five conditions (AND or OR) for a bit device, word device or security device can be set, which is suitable for setting complicated conditions.

Character String Table

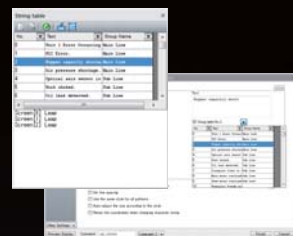

Text for switches, lamps and other parts can be managed centrally using the character string table. Frequently used text can be registered in the table for easy reference and batch modification.

* Switches, lamps, text, and multi text only.

Facilitation of Screen Configuration

Guided Setting Process

With the help of the clear instructions in the dialog, setting can be conducted smoothly and collectively.



A Wider Range of Colors for 3D parts

65,536 colors are available for 3D Parts.

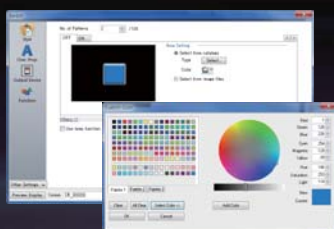

Visualization of Setting

Set conditions can be confirmed on the preview screen before completing setting. By switching the preview screen and setting dialog, the setting can be confirmed easily even on a PC with low resolution.

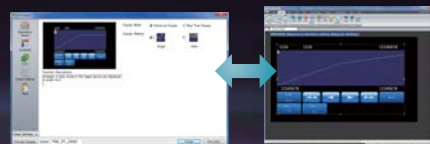

Tool Hints to Support Configuration

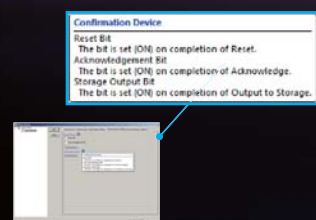

Tool hints are provided at many points to support configuration. When you hover the mouse over the item, a hint for operation will appear. You can learn the procedure for configuration without referring to the manual.

Direct Editing with the Item View

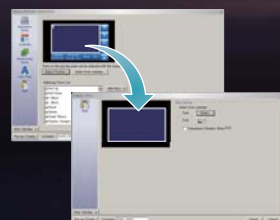

In the item view, an indication range and component parts consisting of various parts including switches are selected. Since there is no need to select various items respectively, smooth and efficient editing is possible.

Optional Units

Extension Units

GUR-00 (Video input 4ch)*
Displays images from video cameras on V9 directly.

GUR-01 (RGB input 1ch)
Displays RGB input on V9.

GUR-02 (RGB output 1ch)
Displays images of V9 on a monitor.

GUR-04 (Video input 1ch)
Displays images from a video camera directly.

GUR-10 (Video input 2ch + RGB input 1ch)*
Displays images from video camera and RGB input on V9 simultaneously.

GUR-11 (RGB input 2ch)*
Displays RGB images such as PC images through two channels on V9 simultaneously.

* Scheduled to be released in April 2016.

Communication Units

CUR-00 OPCN-1	CUR-04 PROFIBUS-DP
CUR-01 T-link	CUR-06 SX bus
CUR-02 CC-Link	CUR-07 DeviceNet
CUR-03 Ethernet	CUR-08 FL-net

Configuration software

V-SFT-6 (Ver.6)
WindowsXP/ XP 64Edition/ Vista 32bit/ Vista 64bit/ Win7 32bit/ Win7 64bit/ Win8 32bit/ Win8 64bit/ Win 8.1 32bit/ Win 8.1 64bit

Cables

Type	Configuration	Connected to
V-CP	RS-232C Modular 8pin D-Sub9pin(F) Length: 3m	PC
V6-BCD	RS-232C Modular 8pin Length: 3m	Barcode reader
V6-MLT	RS-485 Modular 8pin Length: 3m	MONITOUCH V8/V9
V6-TMP	RS-232C/485 Modular 8pin Length: 3·5·10m	Temperature controller, inverter, etc.
UA-FR	Type A Length: 1m	Card reader/writer, USB memory, etc.

DUR-00 (Dedicated optional unit for V9071iW/ V9060iTD)

Used for serial connection with D-Sub9pin.

Other Units

TC-D9 (Terminal converter)
Connects V9 with other units via RS-422/485 terminal.

V9-BT
A replacement lithium battery for V9 series.
*Excluding the V9071iW and V9060iTD.

V7-BT
A replacement lithium battery for the V9071iW, V9060iTD and V8 series.

V9xxx-GS/V9xxx-GSN10
Protection sheets for panels (5 sheets per set). N10 is a non-glare type sheet. See P.25 for details.

D9-D25
Replacement cable for CN1 cable of V6/V7 series.

Panel adapter (PAD-Vxxx)
Used when fitting V9 into V4/GD-80/GD-65/GD-64 panel cutout. Contact our technical helpdesk for details.

V9-ANT
Antenna for V9 models compatible with wireless LAN.

High-end specifications realize smooth

and accurate operation.

General Specifications

Item	V9 Advanced		V9 Standard					
	V9101iW	V9071iW	V9150iX	V9150iXD	V9120iS	V9120iSD		
Power supply	Rated voltage		24VDC		100-240VAC	24VDC	100-240VAC	24VDC
	Permissible range of voltage		±10%		-15%,+10%	±10%	-15%,+10%	±10%
Insulation resistance			DC500V 10MΩ or more					
Physical environment	Ambient temperature		0~50°C ¹⁾		0~40°C ¹⁾		0~50°C ¹⁾	
	Ambient humidity		85%RH or less (without dew condensation) ¹⁾					
	Operation altitude		2,000 meters or lower					
	Atmosphere		Not to be exposed to corrosive gas, or conductive dust					
	Storage temperature		-10~60°C ¹⁾		-10~50°C ¹⁾		-10~60°C ¹⁾	
	Storage humidity		85%RH or less (without dew condensation) ¹⁾					
Contamination level		Level 2						
Mechanical operating conditions	Resistance to oscillation		JIS B 3502 (IEC61131-2) compliant, Vibration frequency: 5~9Hz, Half-amplitude: 3.5mm, Vibration frequency: 9~150Hz, Constant acceleration: 9.8m/s ² (1G), X, Y, Z: 3 directions (10 times each)					
	Resistance to shock		JIS B 3502 (IEC61131-2) compliant, Peak acceleration: 147m/s ² (15G), X,Y,Z:3 directions, 3 times each (18 times in total)					
Electric operating conditions	Resistance to noise		Noise voltage:1,000Vp-p, pulse width:1μs, pulse rise time : 1ns	Noise voltage:1,500Vp-p, pulse width:1μs, pulse rise time : 1ns	Noise voltage:1,000Vp-p, pulse width:1μs, pulse rise time : 1ns	Noise voltage:1,500Vp-p, pulse width:1μs, pulse rise time : 1ns		
	Resistance to static Discharge		Complies with IEC61000-4-2, contact: 6KV, air: 8KV					
Installation conditions	Grounding		Grounding resistance: Less than 100Ω, FG/SG separation	Grounding resistance: Less than 100Ω, FG=SG	Grounding resistance: Less than 100Ω, FG/SG separation			
	Structure		Protection structure: Front case: IP66, TYPE4X/13 ^{7*)8)} (when water-proof gasket is used), Rear case: IP20, single unit, installation method: panel mounting					
	Cooling system		Natural air cooling					
	Dimensions W*H*D (mm)		278.5×198.5×54.4	201.6×147.6×60.3	382.8×312.8×80.8	327.8×261.0×54.9		
Panel cutout (mm)		257.0×183.0(+0.5/-0)	187.2×133.4(+0.5/-0)	369.4×299.4(+0.5/-0)	313.0×246.2(+0.5/-0)			
Case color		Light gray		-		Light gray		
Material		PC resin		Front case: Aluminum, Rear case: PC resin		PC resin		

¹⁾: Wet-bulb temperature should be 39°C or lower to prevent malfunction.

V9 Standard			V9 Lite			
V9100iS	V9100iSD	V9080iSD	V9100iC	V9100iCD	V9080iCD	V9060iTD
100-240VAC			24VDC			24VDC
-15%,+10%			±10%			±10%
DC500V 10MΩ or more			DC500V 10MΩ or more			
0~50°C ¹⁾			0~50°C ¹⁾			
85%RH or less (without dew condensation) ¹⁾			85%RH or less (without dew condensation) ¹⁾			
2,000 meters or lower			2,000 meters or lower			
Not to be exposed to corrosive gas, or conductive dust			Not to be exposed to corrosive gas, or conductive dust			
-10~60°C ¹⁾			-10~60°C ¹⁾			
85%RH or less (without dew condensation) ¹⁾			85%RH or less (without dew condensation) ¹⁾			
Level 2			Level 2			
JIS B 3502 (IEC61131-2) compliant, Vibration frequency: 5~9Hz, Half-amplitude: 3.5mm, Vibration frequency: 9~150Hz, Constant acceleration: 9.8m/s ² (1G), X, Y, Z: 3 directions (10 times each)			JIS B 3502 (IEC61131-2) compliant, Vibration frequency: 5~9Hz, Half-amplitude: 3.5mm, Vibration frequency: 9~150Hz, Constant acceleration: 9.8m/s ² (1G), X, Y, Z: 3 directions (10 times each)			JIS B 3502 (IEC61131-2) compliant, Peak acceleration: 147m/s ² (15G), X,Y,Z:3 directions, 3 times each (18 times in total)
Noise voltage:1,000Vp-p, pulse width:1μs, pulse rise time : 1ns			Noise voltage:1,500Vp-p, pulse width:1μs, pulse rise time : 1ns			Noise voltage:1,000Vp-p, pulse width:1μs, pulse rise time : 1ns
Complies with IEC61000-4-2, contact: 6KV, air: 8KV			Complies with IEC61000-4-2, contact: 6KV, air: 8KV			
Grounding resistance: Less than 100Ω, FG/SG separation			Grounding resistance: Less than 100Ω, FG/SG separation			
Protection structure: Front case: IP66, TYPE4X/13 ^{7*)8)} (when water-proof gasket is used), Rear case: IP20, single unit, installation method: panel mounting			Protection structure: Front case: IP66, TYPE4X/13 ^{7*)8)} (when water-proof gasket is used), Rear case: IP20, single unit, installation method: panel mounting			
Natural air cooling			Natural air cooling			
303.8×231.0×54.0		235.0×180.0×48.9	303.8×231.0×54.0		235.0×180.0×48.9	182.5×138.8×53.0
289.0×216.2(+0.5/-0)		220.5×165.5(+0.5/-0)	289.0×216.2(+0.5/-0)		220.5×165.5(+0.5/-0)	174.0×131.0(+0.5/-0)
Light gray			Light gray			
PC resin			PC resin			

Performance Specifications

Item	V9 Advanced		V9 Standard		
	V9101iW	V9071iW	V9150iX	V9120iS	
Screen memory (FROM)		64MB			
Backup memory (SRAM)		800KB			
Display	Display device		TFT color LCD		
	Resolution		1024×600	800×480	1024×768
	Display size		10.1" Wide	7" Wide	15"
	Colors		16.7 million ²⁾		
	Backlight		LED		
	Backlight life		50,000 hours	100,000 hours	
Touch switch	Type		Capacitance		
Function switch	Quantity		None		
External interface	D-Sub 9-pin (CN1) ³⁾		RS-232C/ RS-422/ RS-485, Asynchronous type, Data length: 7,8 bits, Parity: even, odd, none, Stop bit: 1, 2 bits, Baud rate: 4800, 9600, 19200, 38400, 57600, 76800, 115200,187500*4)bps		
	Modular 8-pin (MJ1/ MJ2)		RS-232C/ RS-422/ RS-485 (two-wire system), ³⁾ Asynchronous type, Data length: 7,8 bits, Parity: even, odd, none, Stop bit: 1, 2 bits, Baud rate: 4800, 9600, 19200, 38400, 57600, 76800, 115200 bps		
	SD card		One card slot provided as standard		
	Ethernet		2ch, Baud rate: 100Mbps, 10Mbps	1ch, Baud rate: 100Mbps, 10Mbps	
	Wireless LAN		Complies with IEEE802.11b/g/n (2.4GHz) ⁵⁾		
	USB		Type A,Type mini-B (Ver.2.0)		
	Sound output		1ch provided as standard	-	
	Clock		Backup period		
Calendar accuracy		Gap ±90 sec. per month (Ambient temperature 25°C)			
Standard	CE marking ⁶⁾		EN61000-6-2, EN61000-6-4		
	UL-cUL ⁷⁾		UL508	UL508, ANSI/ISA12.12.01 ⁹⁾	
	KC		Compliant		
	Radio Act ⁸⁾		Japan: TELEC USA: FCC Canada: IC RSS	EU: R&TTE South Korea: KC	Japan: TELEC

V9 Standard		V9 Lite		
V9100iS	V9080iSD	V9100iC	V9080iCD	V9060iTD
64MB		64MB		
800KB		800KB		
TFT color LCD		TFT color LCD		
800×600		640×480		
10.4"	8.4"	10.4"	8.4"	5.7"
16.7 million ²⁾		16.7 million ²⁾		
LED		LED		
70,000 hours		70,000 hours		
50,000 hours		50,000 hours		
Analog resistance film		Analog resistance film		
8		8		
6		6		
RS-232C/ RS-422/ RS-485, Asynchronous type, Data length: 7,8 bits, Parity: even, odd, none, Stop bit: 1, 2 bits, Baud rate: 4800, 9600, 19200, 38400, 57600, 76800, 115200,187500*4)bps		RS-232C/ RS-422/ RS-485, Asynchronous type, Data length: 7,8 bits, Parity: even, odd, none, Stop bit: 1, 2 bits, Baud rate: 4800, 9600, 19200, 38400, 57600, 76800, 115200,187500*4)bps		
RS-232C/ RS-422/ RS-485 (two-wire system), ³⁾ Asynchronous type, Data length: 7,8 bits, Parity: even, odd, none, Stop bit: 1, 2 bits, Baud rate: 4800, 9600, 19200, 38400, 57600, 76800, 115200 bps		RS-232C/ RS-422/ RS-485 (two-wire system), ³⁾ Asynchronous type, Data length: 7,8 bits, Parity: even, odd, none, Stop bit: 1, 2 bits, Baud rate: 4800, 9600, 19200, 38400, 57600, 76800, 115200 bps		
One card slot provided as standard		One card slot provided as standard		
1ch, Baud rate: 100Mbps, 10Mbps		1ch, Baud rate: 100Mbps, 10Mbps		
Complies with IEEE802.11b/g/n (2.4GHz) ⁵⁾		-		
Type A,Type mini-B (Ver.2.0)		-		
1ch provided as standard		-		
5 years (Ambient temperature 25°C)		5 years (Ambient temperature 25°C)		
Gap ±90 sec. per month (Ambient temperature 25°C. When the battery is backed up)		Gap ±90 sec. per month (Ambient temperature 25°C. When the battery is backed up)		
EN61000-6-2, EN61000-6-4		EN61000-6-2, EN61000-6-4		
UL508, ANSI/ISA12.12.01 ⁹⁾		UL508		UL508, ANSI/ISA12.12.01 ⁹⁾
Compliant		Compliant		
Japan: TELEC		-		

²⁾: Only for pictures, 3D parts and videos. Other items are displayed in 65,536 colors. ³⁾: Optional unit (DUR-00) is required for the V9071iW and V9060iTD. ⁴⁾: Only for Siemens MPI (Incompatible with DUR-00). ⁵⁾: 187,500bps (four-wire system) for the V9071iW and V9060iTD MJ2 only. ⁶⁾: Wireless LAN-compatible products only. ⁷⁾: DC products only. ⁸⁾: V9101iW: Hardware of Ver.c or later V9120iSD/V9100iSD/V9080iSD/V9100iCD/V9080iCD: Hardware of Ver.b or later V9071iW/V9150iXD/V9060iTD:All versions ⁹⁾: V9120iSD/V9100iSD/V9080iSD: Hardware of Ver.b or later V9060iTD: All versions

Dimensions and Part Names

V9 Advanced V9101iW (Unit: mm)

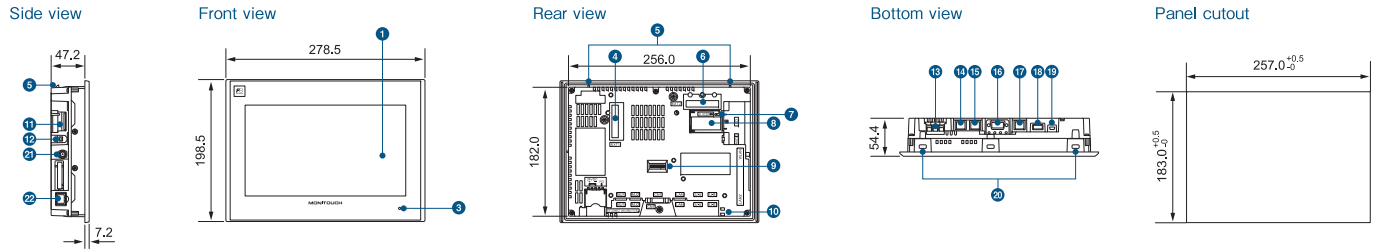

V9 Advanced V9071iW (Unit: mm)

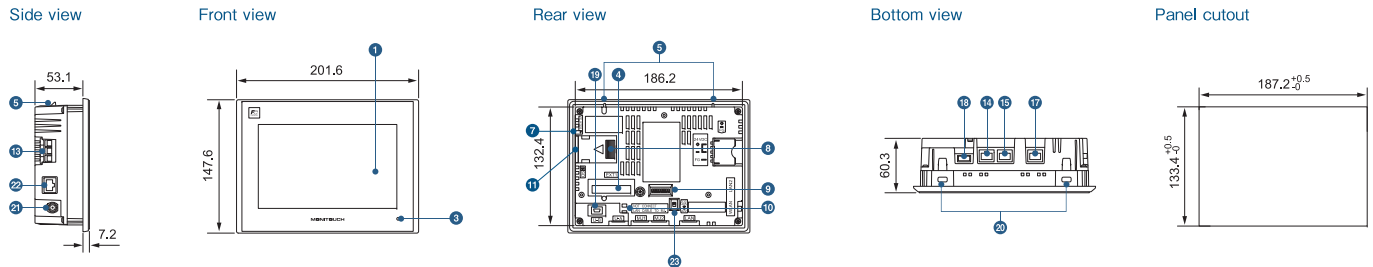

V9 Standard V9150iX (Unit: mm)

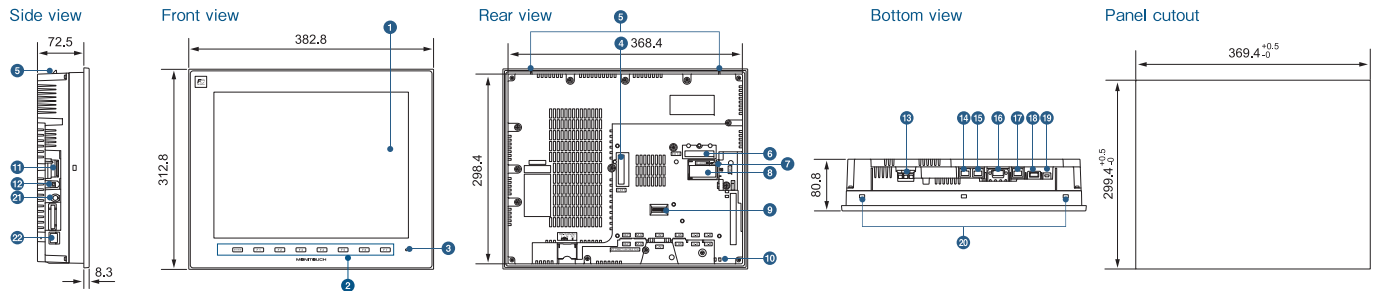

V9 Standard V9120iS (Unit: mm)

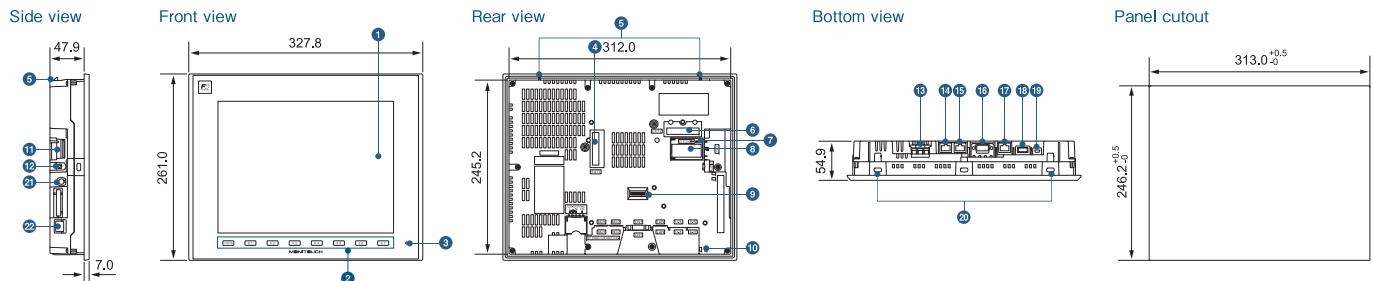

V9 Standard V9100iS (Unit: mm)

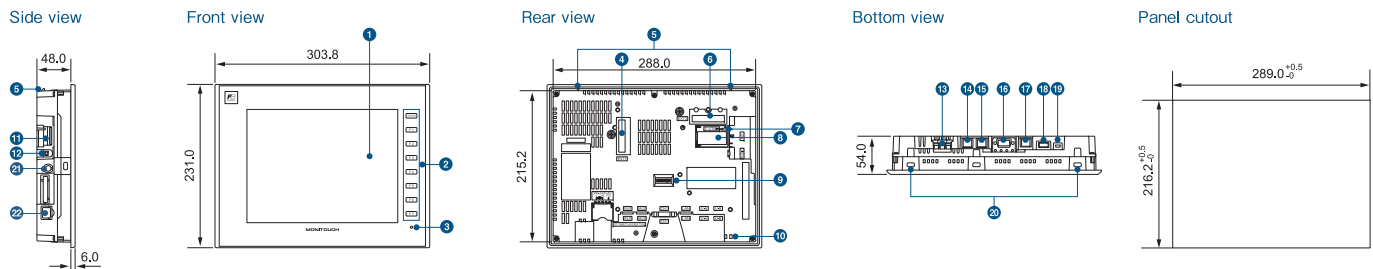

V9 Standard V9080iSD (Unit: mm)

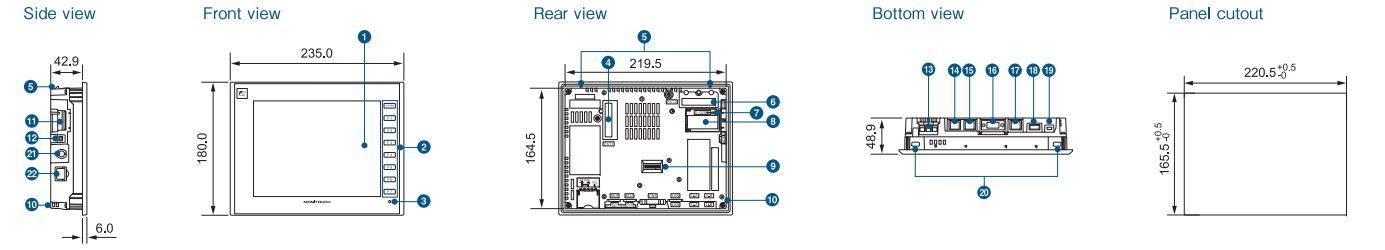

V9 Lite V9100iC (Unit: mm)

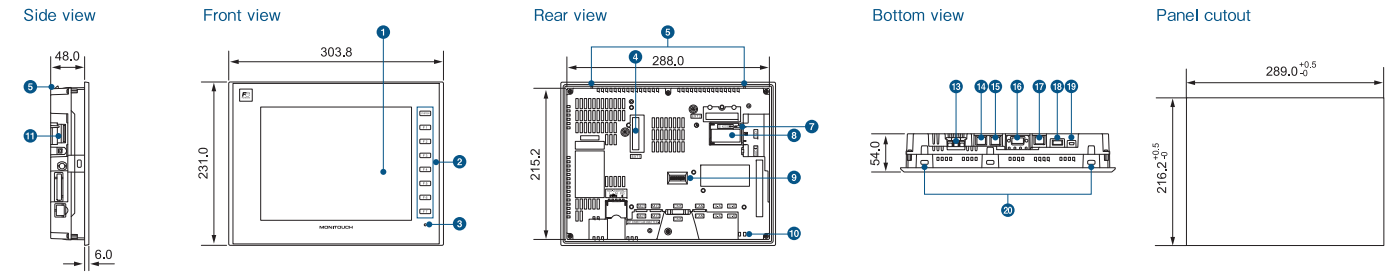

V9 Lite V9080iCD (Unit: mm)

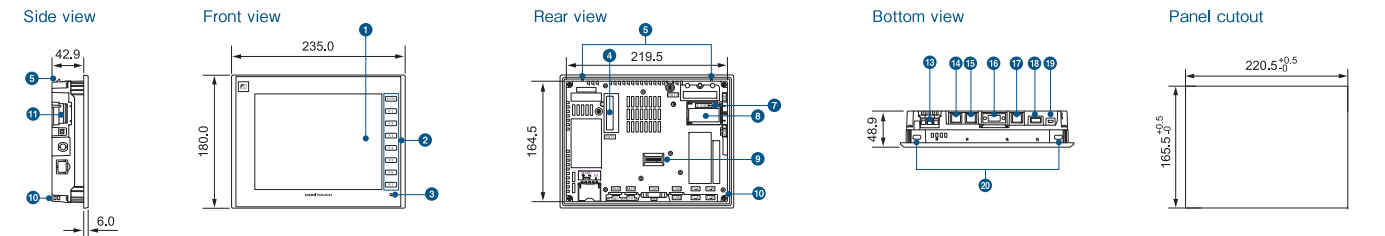

V9 Lite V9060iTD (Unit: mm)

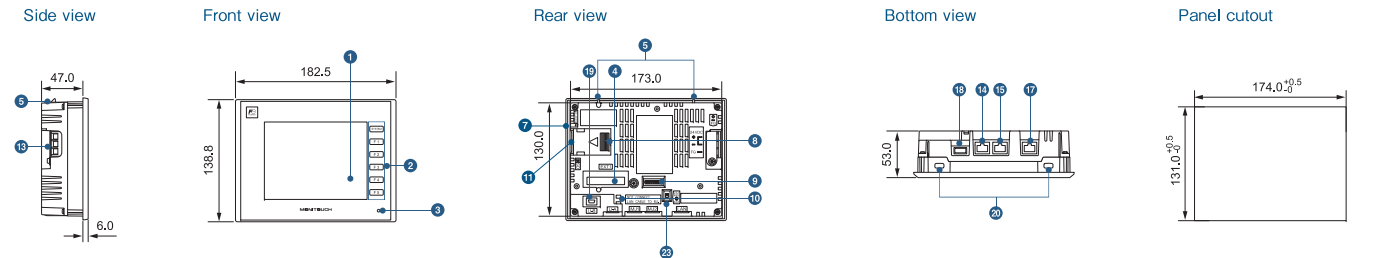

Part Names

- | | | | |
|---------------------------------------|-----------------------------------|-----------------------------------|---|
| 1 Display | 7 SD card access LED | 15 Power input terminal block | 19 USB mini-B (U-B) |
| 2 Function switch | 8 Battery holder | 14 Modular jack 1 (MJ1) | 20 Screw hole |
| 3 Power lamp | 9 DIP switch | 15 Modular jack 2 (MJ2) | 21 Wireless LAN external antenna connector (WLAN) |
| 4 Communication unit connector (EXT1) | 10 USB cable holding hole | 16 PLC connector (CN1) | 22 100BASE-TX/10BASE-T port (LAN2) |
| 5 Fall prevention hook | 11 SD card connector | 17 100BASE-TX/10BASE-T port (LAN) | 23 Slide switch |
| 6 Optional unit connector (EXT2) | 12 Sound output connector (AUDIO) | 18 USB-A (U-A) | |

Remarkable cost effectiveness enabled by

our product lineup and optional units.

Product List

Advanced

Model	Display Size	Resolution	Specification									Delivery Standard: ✓ Made to order: △
			Touch Switch	Video/RGB	AUDIO Output	Wireless LAN	Extended Cable LAN	UL508	CE	KC	Power	
V9101IWRLD	10.1" Wide	1024×600	Capacitance	✓	✓	✓	✓	✓	✓	✓	DC	✓
V9100IWRLD			Analog resistance film	✓	✓	✓	✓	✓	✓	✓		△
V9101IWLD			Capacitance	✓	✓	—	✓	✓	✓	✓		✓
V9100IWLD			Analog resistance film	✓	✓	—	✓	✓	✓	✓		△
V9071IWRLD	Wide	800×480	Capacitance	—	—	✓	✓	✓	✓	✓	DC	✓
V9070IWRLD			Analog resistance film	—	—	✓	✓	✓	✓	✓		△
V9071IWLD			Capacitance	—	—	—	✓	✓	✓	✓		✓
V9070IWLD			Analog resistance film	—	—	—	✓	✓	✓	✓		△

Standard

Model	Display Size	Resolution	Specification									Delivery Standard: ✓ Made to order: △	
			Touch Switch	Video/RGB	AUDIO Output	Wireless LAN	Extended Cable LAN	UL508	CE	KC	Power		
V9150iX	15"	1024×768	Analog resistance film	✓	✓	—	—	—	—	✓	AC	✓	
V9150iXD			Analog resistance film	✓	✓	—	—	✓	✓	✓		DC	△
V9150iXLD			Analog resistance film	✓	✓	—	—	✓	✓	✓			△
V9150iXRD			Analog resistance film	✓	✓	✓ ^{*1}	—	—	—	—		—	△
V9120iS	12.1"	800×600	Analog resistance film	✓	✓	—	—	—	—	✓	AC	✓	
V9120iSD			Analog resistance film	✓	✓	—	—	✓	✓	✓		DC	△
V9120iSLD			Analog resistance film	✓	✓	—	✓	✓	✓	✓			△
V9120iSRD			Analog resistance film	✓	✓	✓ ^{*1}	—	✓	—	—		—	△
V9100iS	10.4"	800×600	Analog resistance film	✓	✓	—	—	—	—	—	AC	✓	
V9100iSD			Analog resistance film	✓	✓	—	—	✓	✓	✓		DC	△
V9100iSLD			Analog resistance film	✓	✓	—	✓	✓	✓	✓			△
V9100iSRD			Analog resistance film	✓	✓	✓ ^{*1}	—	✓	—	—		—	△
V9080iSD	8.4"	800×600	Analog resistance film	✓	✓	—	—	✓	✓	✓	DC	✓	
V9080iSLD			Analog resistance film	✓	✓	—	✓	✓	✓	✓		△	
V9080iSRD			Analog resistance film	✓	✓	✓ ^{*1}	—	✓	—	—		△	

Lite

Model	Display Size	Resolution	Specification									Delivery Standard: ✓ Made to order: △
			Touch Switch	Video/RGB	AUDIO Output	Wireless LAN	Extended Cable LAN	UL508	CE	KC	Power	
V9100iC	10.4"	640×480	Analog resistance film	—	—	—	—	—	—	✓	AC	✓
V9100iCD	8.4"	640×480	Analog resistance film	—	—	—	—	✓	✓	✓	DC	✓
V9080iCD	8.4"	640×480	Analog resistance film	—	—	—	—	✓	✓	✓	DC	✓
V9060iTD	5.7"	640×480	Analog resistance film	—	—	—	—	✓	✓	✓	DC	✓

*1: Only for use in Japan.

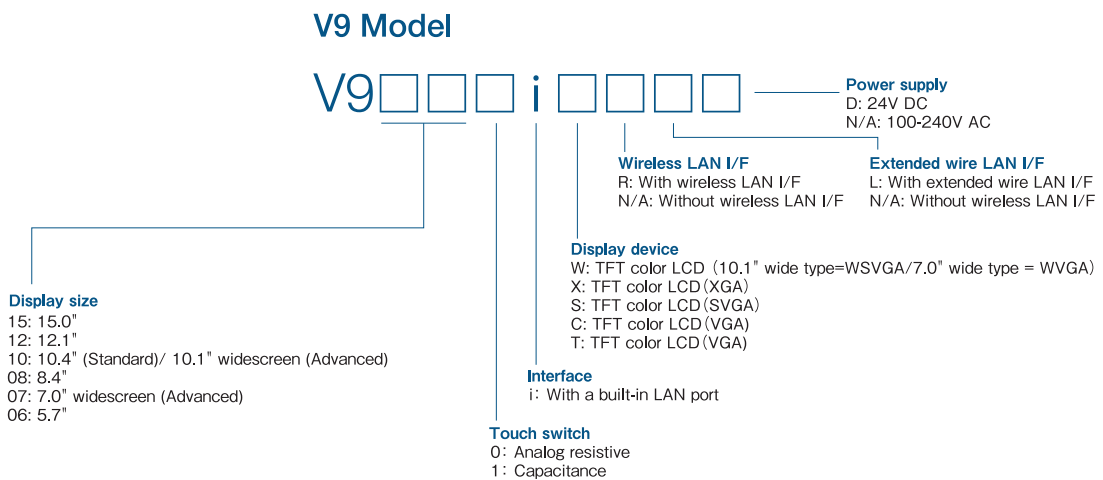

Optional Unit List

Type	Product	Compatible Model									
		Advanced		Standard				Lite			
		V9101iW	V9071iW	V9150iX	V9120iS	V9100iS	V9080iS	V9100iC	V9080iC	V9060iT	
Configuration Software											
V-SFT-6	V8/V9 design tool software Ver.6 (Manual not included)	✓	✓	✓	✓	✓	✓	✓	✓	✓	
Extension Units											
GUR-00 ^{*1}	Video 4ch input	✓		✓	✓	✓	✓				
GUR-01	RGB 1ch input	✓		✓	✓	✓	✓				
GUR-02	RGB 1ch output	✓		✓	✓	✓	✓				
GUR-04	Video 1ch input	✓		✓	✓	✓	✓				
GUR-10 ^{*1}	Video 2ch input/ RGB 1ch input	✓		✓	✓	✓	✓				
GUR-11 ^{*1}	RGB 2ch input	✓		✓	✓	✓	✓				
DUR-00	V9071iW/ V9060iTD optional unit		✓							✓	
Communication Units											
CUR-00	OPCN-1	✓	✓	✓	✓	✓	✓	✓	✓	✓	
CUR-01	T-link	✓	✓	✓	✓	✓	✓	✓	✓	✓	
CUR-02	CC-Link	✓	✓	✓	✓	✓	✓	✓	✓	✓	
CUR-03	Ethernet	✓	✓	✓	✓	✓	✓	✓	✓	✓	
CUR-04	PROFIBUS-DP	✓	✓	✓	✓	✓	✓	✓	✓	✓	
CUR-06	SX bus	✓	✓	✓	✓	✓	✓	✓	✓	✓	
CUR-07	DeviceNet	✓	✓	✓	✓	✓	✓	✓	✓	✓	
CUR-08	FL-net	✓	✓	✓	✓	✓	✓	✓	✓	✓	
Cables											
V-CP	Screen transfer cable (3m)	✓	✓	✓	✓	✓	✓	✓	✓	✓	
UA-FR	USB-A extension cable (1m)	✓	✓	✓	✓	✓	✓	✓	✓	✓	
V6-MLT	Multi-link 2 master cable (3m)	✓	✓	✓	✓	✓	✓	✓	✓	✓	
V6-TMP	Temperature controller cable (3m)	✓	✓	✓	✓	✓	✓	✓	✓	✓	
V6-TMP-5M	Temperature controller cable (5m)	✓	✓	✓	✓	✓	✓	✓	✓	✓	
V6-TMP-10M	Temperature controller cable (10m)	✓	✓	✓	✓	✓	✓	✓	✓	✓	
V6-BCD	Barcode reader cable (3m)	✓	✓	✓	✓	✓	✓	✓	✓	✓	
D9-MB-CPUQ-2M	MITSUBISHI ELECTRIC A series / QnA series CPU (Dsub25) RS-422	✓	△ ^{*2}	✓	✓	✓	✓	✓	✓	✓	△ ^{*2}
D9-MB-CPUQ-3M		✓	△ ^{*2}	✓	✓	✓	✓	✓	✓	✓	△ ^{*2}
D9-MB-CPUQ-5M		✓	△ ^{*2}	✓	✓	✓	✓	✓	✓	✓	△ ^{*2}
D9-MB-CPUQ-10M		✓	△ ^{*2}	✓	✓	✓	✓	✓	✓	✓	△ ^{*2}
D9-MB-CPUQ-15M		✓	△ ^{*2}	✓	✓	✓	✓	✓	✓	✓	△ ^{*2}
D9-QCPU2-2M	MITSUBISHI ELECTRIC Q series CPU (Mini DIN6) RS-232C	✓	△ ^{*2}	✓	✓	✓	✓	✓	✓	✓	△ ^{*2}
D9-QCPU2-3M		✓	△ ^{*2}	✓	✓	✓	✓	✓	✓	✓	△ ^{*2}
D9-QCPU2-5M		✓	△ ^{*2}	✓	✓	✓	✓	✓	✓	✓	△ ^{*2}
D9-QCPU2-10M		✓	△ ^{*2}	✓	✓	✓	✓	✓	✓	✓	△ ^{*2}
D9-QCPU2-15M		✓	△ ^{*2}	✓	✓	✓	✓	✓	✓	✓	△ ^{*2}
D9-MI2-09-2M	MITSUBISHI ELECTRIC link unit (Dsub9) RS-232C	✓	△ ^{*2}	✓	✓	✓	✓	✓	✓	✓	△ ^{*2}
D9-MI2-09-3M		✓	△ ^{*2}	✓	✓	✓	✓	✓	✓	✓	△ ^{*2}
D9-MI2-09-5M		✓	△ ^{*2}	✓	✓	✓	✓	✓	✓	✓	△ ^{*2}
D9-MI2-09-10M		✓	△ ^{*2}	✓	✓	✓	✓	✓	✓	✓	△ ^{*2}
D9-MI2-09-15M		✓	△ ^{*2}	✓	✓	✓	✓	✓	✓	✓	△ ^{*2}
D9-MI4-FX-2M	MITSUBISHI ELECTRIC FX series CPU (Mini DIN8) RS-422	✓	△ ^{*2}	✓	✓	✓	✓	✓	✓	✓	△ ^{*2}
D9-MI4-FX-3M		✓	△ ^{*2}	✓	✓	✓	✓	✓	✓	✓	△ ^{*2}
D9-MI4-FX-5M		✓	△ ^{*2}	✓	✓	✓	✓	✓	✓	✓	△ ^{*2}
D9-MI4-FX-10M		✓	△ ^{*2}	✓	✓	✓	✓	✓	✓	✓	△ ^{*2}
D9-MI4-FX-15M		✓	△ ^{*2}	✓	✓	✓	✓	✓	✓	✓	△ ^{*2}
D9-FU-SPHCPU-2M	FUJI ELECTRIC SPH CPU RS-485 (4-wire)	✓	△ ^{*2}	✓	✓	✓	✓	✓	✓	✓	△ ^{*2}
D9-FU-SPHCPU-3M		✓	△ ^{*2}	✓	✓	✓	✓	✓	✓	✓	△ ^{*2}
D9-FU-SPHCPU-5M		✓	△ ^{*2}	✓	✓	✓	✓	✓	✓	✓	△ ^{*2}
D9-FU-SPBCPU-2M		✓	△ ^{*2}	✓	✓	✓	✓	✓	✓	✓	△ ^{*2}
D9-FU-SPBCPU-3M		✓	△ ^{*2}	✓	✓	✓	✓	✓	✓	✓	△ ^{*2}
D9-FU-SPBCPU-5M	✓	△ ^{*2}	✓	✓	✓	✓	✓	✓	✓	△ ^{*2}	
D9-D25	Dsub9-Dsub25 conversion cable (0.3m)	✓	△ ^{*2}	✓	✓	✓	✓	✓	✓	✓	△ ^{*2}
MJ2-PLC	MJ2-Dsub25 conversion cable	✓									✓
Communication Terminal Block											
TC-D9	Terminal converter for V9/V8	✓	△ ^{*2}	✓	✓	✓	✓	✓	✓	✓	△ ^{*2}
Battery											
V9-BT	Replacement battery for V9	✓		✓	✓	✓	✓	✓	✓	✓	✓
V7-BT	Replacement battery for V9071iW/V9060iTD/V8		✓								✓
Wireless LAN Antenna											
V9-ANT	V9 external antenna with cable (3m)	✓	✓								
Protection Sheets											
V715-GS	V9150iX/V815/V715 Surface protection sheet			✓							
V715-GSN10	V9150iX/V815/V715 Surface protection sheet (Non-glare)			✓							
V912S-GS	V9120iS protection sheets				✓						
V912S-GSN10	V9120iS protection sheets (Non-glare)				✓						
V910S-GS	V9100iS/V9100iC protection sheets					✓					
V910S-GSN10	V9100iS/V9100iC protection sheets (Non-glare)					✓					
V908S-GS	V9080iS/V9080iC protection sheets						✓				
V908S-GSN10	V9080iS/V9080iC protection sheets (Non-glare)						✓				
V906T-GS	V9060iTD protection sheets										✓
V906T-GSN10	V9060iTD protection sheets (Non-glare)										✓

*1 : Scheduled to be released in April 2016.

*2 : Optional unit DUR-00 is required.

V8 Series – scaling new heights in performance, usability and connectivity.

MONITOUCH V8 series

Provided with revolutionary features for production sites such as 8-way communication and 16-million-color high-resolution video display, the V8 series has expanded the potential of programmable operator interface panels. The screen programs and panels of the V7 series are also compatible with the V8 series.

Product Lineup

High performance model

15.0 inches	12.1 inches	10.4 inches	8.4 inches
			
V815iXN	V812iSN V812SN	V810iSN V810SN	V810iTn V810TN

Standard model

10.4 inches	8.4 inches	7.7 inches	5.7 inches		
					
V810iCN V810CN	V808iCDN V808CDN	V808iCHx V808CHx	V806iTDN V806TDN	V806iCDN V806CDN	V806iMDN V806MDN

V8 Model

V8□□□□□□N

Display size
15: 15 inches
12: 12.1 inches
10: 10.4 inches
08: 8.4 inches
06: 5.7 inches

Display device
X: TFT color LCD (XGA)
S: TFT color LCD (SVGA)
T: TFT color LCD (VGA)*1
C: TFT color LCD (VGA)*1
M: TFT monochrome LCD (QVGA)

Touch switch
N/A: Analog resistive
M: Matrix resistive

Interface
N/A: Without a built-in LAN port / An optional port is not available.
i: With a built-in LAN port / An optional port is available.*2

V808CH Model

V808□CH□□

Interface
N/A: Without a built-in LAN port
i: With a built-in LAN port

Key switch	Deadman switch	
	Switch type	External output
0	Momentary	—
1	Equipped	—
2	—	3-position 1 contact
3	Equipped	3-position 1 contact
4	—	3-position 2 contacts

Specifications

Item	V815iXN	V812iSN	V812SN	V810iSN	V810SN	V810iTn	V810TN	V810iCN	V810CN	V808iSDN	V808SDN	V808iCDN	V808CDN
Basic specification													
Display size	15"	12.1"		10.4"				8.4"					
Display device	TFT color												
Resolution W:H (dots)	1024×768	800×600		640×480				800×600		640×480			
Colors	65,536 colors (without blinks) / 32,768 colors (with blinks)												
Screen memory	FROM (12.5MB)								FROM (4.5MB)	FROM (12.5MB)		FROM (4.5MB)	
Backup memory	SRAM (512KB)								SRAM (128KB)	SRAM (512KB)		SRAM (128KB)	
D-Sub 9-pin CN1	RS-232C, RS-422/485, Asynchronous, Data length: 7.8 bits, Parity: even, odd, none, Stop bit: 1.2 bits, Baud rate: 4800, 9600, 19200, 38400, 57600, 76800, 115200, 187500** bps												
Modular 8-pin MJ1/MJ2	RS-232C, RS-422/485 (two-wire system), Asynchronous, Data length: 7.8 bits, Parity: even, odd, none, Stop bit: 1.2 bits, Baud rate: 4800, 9600, 19200, 38400, 57600, 76800, 115200 bps												
Interface													
Ethernet	100BASE-TX/10BASE-T Built-in	Option (CUN-03-3)	100BASE-TX/10BASE-T Built-in	Option (CUN-03-3)	100BASE-TX/10BASE-T Built-in	Option (CUN-03-3)	100BASE-TX/10BASE-T Built-in	Option (CUN-03-3)	100BASE-TX/10BASE-T Built-in	Option (CUN-03-3)	100BASE-TX/10BASE-T Built-in	Option (CUN-03-3)	Option (CUN-03-3)
Communication I/F	Equipped												
Expansion I/F	Equipped	—	Equipped	—	Equipped	—	Equipped	—	Equipped	—	Equipped	—	
CF card I/F	Equipped												
USB I/F	Type A and B (Ver1.1)												
Options													
Video (4ch)	GU-00	—	GU-00	—	GU-00	—	GU-00	—	GU-00	—	GU-00	—	
RGB input	GU-01	—	GU-01	—	GU-01	—	GU-01	—	GU-01	—	GU-01	—	
RGB output	GU-02	—	GU-02	—	GU-02	—	GU-02	—	GU-02	—	GU-02	—	
Video (2ch)+RGB input	GU-10	—	GU-10	—	GU-10	—	GU-10	—	GU-10	—	GU-10	—	
RGB input (2ch)	GU-11	—	GU-11	—	GU-11	—	GU-11	—	GU-11	—	GU-11	—	
Sound output	GU-00~03	—	GU-00~03	—	GU-00~03	—	GU-00~03	—	GU-00~03	—	GU-00~03	—	
Communication unit	CUN-00, CUN-01, CUN-02-2, CUN-03-3, CUN-04, CUN-06, CUN-07, CUN-08												
I/O unit	V-I/O												
CE Marking*2	EN61000-6-2, EN61000-6-4												
UL·cUL*3	UL508	UL508/UL1604*4											
Marine Standards*5	NK,LR,DNV,ABS,BV,CCS	NK,BV,CCS		NK,LR,DNV,ABS,BV,CCS,GL				—		NK,LR,DNV,ABS,BV,CCS,GL		—	
RoHS directive	Complied												

Item	V806iTDN	V806TDN	V806iCDN	V806CDN	V806iMDN	V806MDN
Basic specification						
Display size	5.7"					
Display device	TFT color			TFT monochrome		
Resolution W:H (dots)	320×240					
Colors	65,536 colors (without blinks)			32,768 colors (with blinks)		16 grayscale (with blinks)
Screen memory	FROM (4.5MB)					
Backup memory	SRAM (512KB)	SRAM (128KB)	SRAM (512KB)	SRAM (128KB)	SRAM (512KB)	SRAM (128KB)
D-Sub 9-pin CN1*	RS-232C, RS-422/485, Asynchronous, Data length: 7.8 bits, Parity: even, odd, none, Stop bit: 1.2 bits, Baud rate: 4800, 9600, 19200, 38400, 57600, 76800, 115200 bps					
Modular 8-pin MJ1/MJ2*	RS-232C, RS-422/485 (two-wire system), Asynchronous, Data length: 7.8 bits, Parity: even, odd, none, Stop bit: 1.2 bits, Baud rate: 4800, 9600, 19200, 38400, 57600, 76800, 115200, 187500** bps					
Interface						
Ethernet	100BASE-TX/10BASE-T Built-in	Option (CUN-03-3)	100BASE-TX/10BASE-T Built-in	Option (CUN-03-3)	100BASE-TX/10BASE-T Built-in	Option (CUN-03-3)
Communication I/F	Equipped					
Extension I/F	—					
CF card I/F	Equipped*					
USB I/F	Type A and B (Ver1.1)					
Options						
Video (4ch)	—					
RGB input	—					
RGB output	—					
Video (2ch)+RGB input	—					
RGB input (2ch)	—					
Sound output	—					
Communication unit	CUN-00, CUN-01, CUN-02-2, CUN-03-3, CUN-04, CUN-06, CUN-07, CUN-08					
I/O unit	V-I/O					
CE Marking	EN61000-6-2, EN61000-6-4					
UL·cUL	UL508/UL1604*4					
Marine Standards*5	NK,LR,DNV,ABS,BV,CCS,GL					
RoHS directive	Complied					

Item	V808iCHx	V808CHx
Basic specification		
Display size	7.5"	
Display device	TFT color	
Resolution W:H (dots)	640×480	
Colors	65,536 colors (without blinks) / 32,768 colors (with blinks)	
Screen memory	FROM (12.5MB)	FROM (4.5MB)
Backup memory	SRAM (512KB)	SRAM (128KB)
Interface		
TB2	RS-232C, Asynchronous, Data length: 7.8 bits, Parity: even, odd, none, Stop bit: 1.2 bits, Baud rate: 4800, 9600, 19200, 38400, 57600, 76800, 115200 bps	
TB3	RS-422/485, Asynchronous, Data length: 7.8 bits, Parity: even, odd, none, Stop bit: 1.2 bits, Baud rate: 4800, 9600, 19200, 38400, 57600, 76800, 115200, 187500** bps	
Ethernet	100BASE-TX/10BASE-T	—
CF card I/F	Equipped	
USB I/F	Type B (Ver1.1)	
Function specification		
No. of switches	12 (4: For external output)	
Switch type	Membrane switch	
Mechanical life	One million times or more	
Emergency stop switch specification		
Switch type	Push lock type (b-contact, 2 circuits)	
Mechanical life	100,000 times or more	
Rated voltage	24VDC	
Rated current	1A (load resistance)	
Key switch specification		
Contact point	a-contact, 1 circuit	
Mechanical life	250,000 times or more	
Electrical life	100,000 times or more (Switching frequency: 1,200 times/h)	
Deadman switch specification		
3-position	Switch type	3-position output (a-contact, 2 circuits**)
	Mechanical life	Off-On: One million times or more, Off-ON-OFF (direct circuit): 100 thousand times
	Rated voltage	24VDC
Momentary	Rated current	1A (load resistance)
	Switch type	Momentary switch
Momentary	One million times or more	
Compatibility		
CE Marking	EN61000-6-2, EN61000-6-4	
UL·cUL	UL508*7	
RoHS directive	Complied	

*1: QVGA for V806.
*2: No optional port for V810iC, V808iC or V806i.

*1: Only when connected with SIEMENS MPI/PPI. *2: Only with 24VDC models. *3: Please contact us for a unit that complies with the marine standards.
*4: Please contact us for a unit that complies with UL1604. *5: Only when connected with SIEMENS MPI/PPI (MJ2 only). Not available for D-Sub 9 pin (option).
*6: Only when equipped with DUN-10 (option). *7: Please contact our sales department for a unit that complies with UL508. *8: MJ2 is compatible with RS-422 (4-wire).
*9: a-contact: 2 circuits for CH4 and 1 circuit for CH2 and CH3 of V808(i).

Wide range of products and optional units

for expanding performance.

Dimensions and Part Names

V815iXN

(Unit:mm)

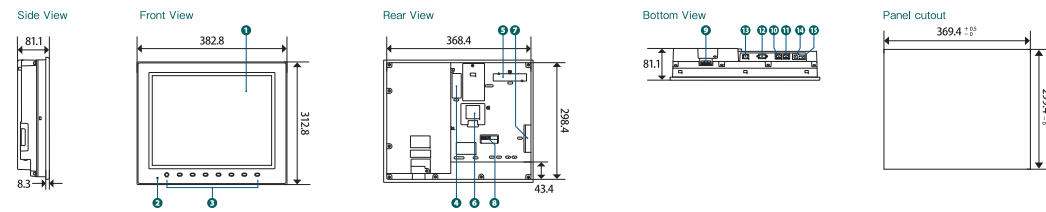

V812iSN / V812SN

(Unit:mm)

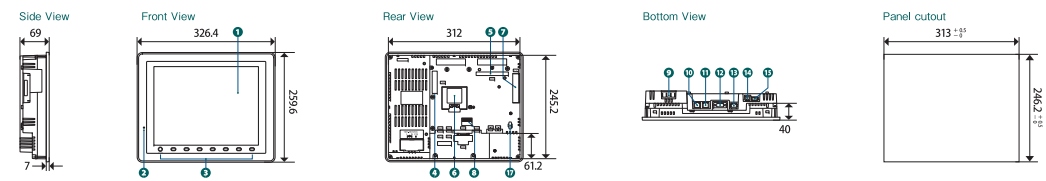

V810iSN / V810SN / V810iTN / V810TN / V810iCN / V810CN

(Unit:mm)

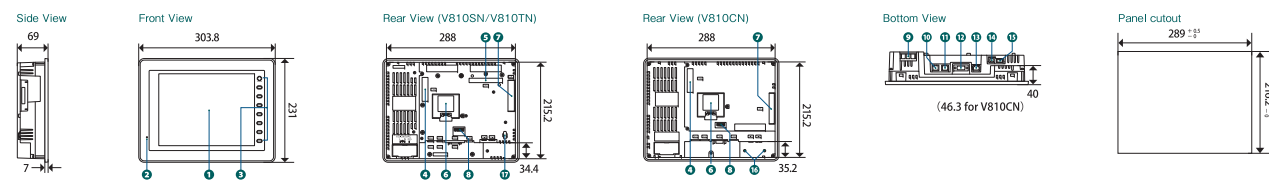

V808iSDN / V808SDN / V808iCDN / V808CDN

(Unit:mm)

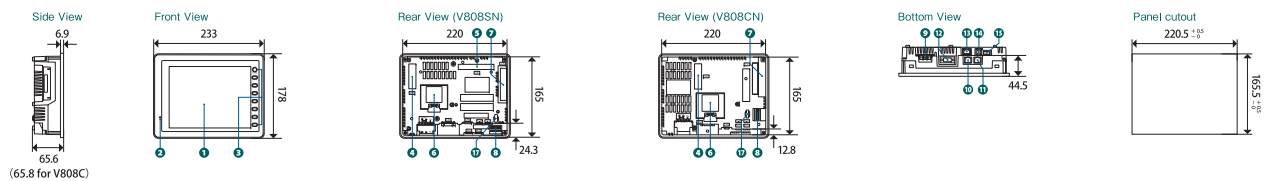

V806iTDN / V806TDN / V806iCDN / V806CDN / V806iMDN / V806MDN

(Unit:mm)

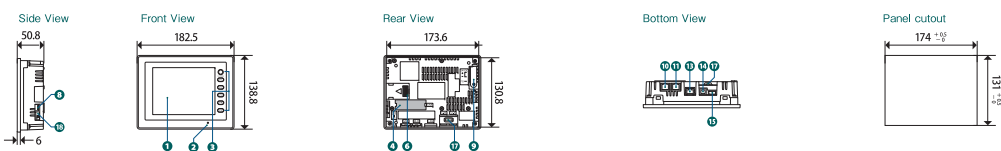

V808iCH / V808CH

(Unit:mm)

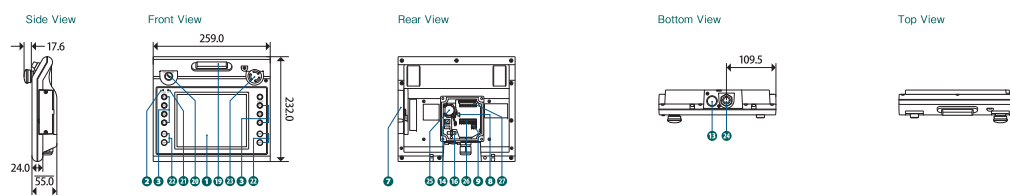

Part Names

- ① Display
- ② Power lamp
- ③ Function switch
- ④ Connector for communication unit (CN5)
- ⑤ Connector for optional unit (CN7)
- ⑥ Battery holder
- ⑦ CF card slot (CF)
- ⑧ DIP switch
- ⑨ Power supply (TB1)
- ⑩ Modular 8-pin for serial port (MJ2)
- ⑪ Modular 8-pin for serial port (MJ2)
- ⑫ D-sub9 pin for serial port (CN1)
- ⑬ 100BASE-TX/10BASE-T port (LAN)
- ⑭ USB-B (U-B)
- ⑮ USB-A (U-A)
- ⑯ Screw hole for fixing USB cable lock
- ⑰ Inlet port for fixing USB cable
- ⑱ Slide switch
- ⑲ Deadman switch
- ⑳ Key switch
- ㉑ Operation lamp
- ㉒ External output switch
- ㉓ Emergency stop switch
- ㉔ Cable insertion port
- ㉕ Battery
- ㉖ Terminal block (TB2)
- ㉗ Terminal block (TB3)

Optional Unit List

Type	Product	Compatible Model																				
		V815		V812		V810				V808				V806								
		iX	iS	S	iS	S	IT	T	IC	C	iS	S	IC	C	ICH	CH	IT	T	IC	C	IM	M
Configuration Software																						
V-SFT-5(CD)	Configuration Software for V8 - V4 series (without the manual) Ver.5	✓	✓	✓	✓	✓	✓	✓	✓	✓	✓	✓	✓	✓	✓	✓	✓	✓	✓	✓	✓	✓
Communication Units																						
CUN-00	OPCN-1	✓	✓	✓	✓	✓	✓	✓	✓	✓	✓	✓	✓	✓	✓	✓	✓	✓	✓	✓	✓	✓
CUN-01	T-Link	✓	✓	✓	✓	✓	✓	✓	✓	✓	✓	✓	✓	✓	✓	✓	✓	✓	✓	✓	✓	✓
CUN-02-2	CC-Link	✓	✓	✓	✓	✓	✓	✓	✓	✓	✓	✓	✓	✓	✓	✓	✓	✓	✓	✓	✓	✓
CUN-03-3	Ethernet	✓	✓	✓	✓	✓	✓	✓	✓	✓	✓	✓	✓	✓	✓	✓	✓	✓	✓	✓	✓	✓
CUN-04	PROFIBUS-DP	✓	✓	✓	✓	✓	✓	✓	✓	✓	✓	✓	✓	✓	✓	✓	✓	✓	✓	✓	✓	✓
CUN-06	SX bus	✓	✓	✓	✓	✓	✓	✓	✓	✓	✓	✓	✓	✓	✓	✓	✓	✓	✓	✓	✓	✓
CUN-07	Device Net	✓	✓	✓	✓	✓	✓	✓	✓	✓	✓	✓	✓	✓	✓	✓	✓	✓	✓	✓	✓	✓
CUN-08	FL-net Ver.2(OPCN-2)	✓	✓	✓	✓	✓	✓	✓	✓	✓	✓	✓	✓	✓	✓	✓	✓	✓	✓	✓	✓	✓
Optional units																						
GU-00	Video 4ch input/ Sound output	✓	✓	✓	✓	✓	✓	✓	✓	✓	✓	✓	✓	✓	✓	✓	✓	✓	✓	✓	✓	✓
GU-01	RGB 1ch input/ Sound output	✓	✓	✓	✓	✓	✓	✓	✓	✓	✓	✓	✓	✓	✓	✓	✓	✓	✓	✓	✓	✓
GU-02	RGB 1ch output/audio output	✓	✓	✓	✓	✓	✓	✓	✓	✓	✓	✓	✓	✓	✓	✓	✓	✓	✓	✓	✓	✓
GU-03	Sound output	✓	✓	✓	✓	✓	✓	✓	✓	✓	✓	✓	✓	✓	✓	✓	✓	✓	✓	✓	✓	✓
GU-10	Video 2ch input/ RGB 1ch input	✓	✓	✓	✓	✓	✓	✓	✓	✓	✓	✓	✓	✓	✓	✓	✓	✓	✓	✓	✓	✓
GU-11	RGB 2ch input	✓	✓	✓	✓	✓	✓	✓	✓	✓	✓	✓	✓	✓	✓	✓	✓	✓	✓	✓	✓	✓
DUN-10	Option unit for V806N (Dsub9+CF card)																✓	✓	✓	✓	✓	✓
Cables																						
V-CP	Screen program transfer cable (3m)	✓	✓	✓	✓	✓	✓	✓	✓	✓	✓	✓	✓	✓	✓	✓	✓	✓	✓	✓	✓	✓
UA-FR	USB-A panel surface fixing cable (1m)	✓	✓	✓	✓	✓	✓	✓	✓	✓	✓	✓	✓	✓	✓	✓	✓	✓	✓	✓	✓	✓
UB-FR	USB-B panel surface fixing cable (1m)	✓	✓	✓	✓	✓	✓	✓	✓	✓	✓	✓	✓	✓	✓	✓	✓	✓	✓	✓	✓	✓
V6-MLT	Multi-link 2 master cable (3m)	✓	✓	✓	✓	✓	✓	✓	✓	✓	✓	✓	✓	✓	✓	✓	✓	✓	✓	✓	✓	✓
V6-TMP	Temperature controller cable (3.5,10m)	✓	✓	✓	✓	✓	✓	✓	✓	✓	✓	✓	✓	✓	✓	✓	✓	✓	✓	✓	✓	✓
V6-BCD	Barcode reader cable(3m)	✓	✓	✓	✓	✓	✓	✓	✓	✓	✓	✓	✓	✓	✓	✓	✓	✓	✓	✓	✓	✓
MJ-D25	MJ-Dsub25 conversion cable	✓	✓	✓	✓	✓	✓	✓	✓	✓	✓	✓	✓	✓	✓	✓	✓	✓	✓	✓	✓	✓
MJ2-PLC	MJ2-Dsub25 conversion cable	✓	✓	✓	✓	✓	✓	✓	✓	✓	✓	✓	✓	✓	✓	✓	✓	✓	✓	✓	✓	✓
D9-MB-CPUQ	mitsubishi electric A/ QnA series CPU RS-422 (2.3.5,10,15m)	✓	✓	✓	✓	✓	✓	✓	✓	✓	✓	✓	✓	✓	✓	✓	✓	✓	✓	✓	✓	✓
D9-QCPU2	mitsubishi electric Q series CPU RS-232C (2.3.5,10,15m)	✓	✓	✓	✓	✓	✓	✓	✓	✓	✓	✓	✓	✓	✓	✓	✓	✓	✓	✓	✓	✓
D9-MI2-09	mitsubishi electric link unit RS-232C (2.3.5,10,15m)	✓	✓	✓	✓	✓	✓	✓	✓	✓	✓	✓	✓	✓	✓	✓	✓	✓	✓	✓	✓	✓
D9-MI4-FX	mitsubishi electric FX series CPU RS-422 (2.3.5,10,15m)	✓	✓	✓	✓	✓	✓	✓	✓	✓	✓	✓	✓	✓	✓	✓	✓	✓	✓	✓	✓	✓
D9-FU-SPHCPU	FUJI ELECTRIC SPH CPU RS-485 (4-wire) (2.3.5m)	✓	✓	✓	✓	✓	✓	✓	✓	✓	✓	✓	✓	✓	✓	✓	✓	✓	✓	✓	✓	✓
D9-FU-SPBCPU	FUJI ELECTRIC SPB CPU RS-485 (4-wire) (2.3.5m)	✓	✓	✓	✓	✓	✓	✓	✓	✓	✓	✓	✓	✓	✓	✓	✓	✓	✓	✓	✓	✓
V706-ACPU	mitsubishi electric A/ QnA series CPU RS-422 (2.3.5m)	✓	✓	✓	✓	✓	✓	✓	✓	✓	✓	✓	✓	✓	✓	✓	✓	✓	✓	✓	✓	✓
MJ2-MI4FX	mitsubishi electric FX series CPU RS-422 (2.3.5m)	✓	✓	✓	✓	✓	✓	✓	✓	✓	✓	✓	✓	✓	✓	✓	✓	✓	✓	✓	✓	✓
MJ2-FU-SPHCPU	FUJI ELECTRIC SPH CPU RS-485 (4-wire) (2.3.5m)	✓	✓	✓	✓	✓	✓	✓	✓	✓	✓	✓	✓	✓	✓	✓	✓	✓	✓	✓	✓	✓
MJ2-FU-SPBCPU	FUJI ELECTRIC SPB CPU RS-485 (4-wire)	✓	✓	✓	✓	✓	✓	✓	✓	✓	✓	✓	✓	✓	✓	✓	✓	✓	✓	✓	✓	✓
V8H-C	External connection cable for V808CH (3.5,15,20m)	✓	✓	✓	✓	✓	✓	✓	✓	✓	✓	✓	✓	✓	✓	✓	✓	✓	✓	✓	✓	✓
D9-D25	Dsub9-Dsub25 conversion cable (0.3m)	✓	✓	✓	✓	✓	✓	✓	✓	✓	✓	✓	✓	✓	✓	✓	✓	✓	✓	✓	✓	✓
D9-D15	Dsub9-Dsub15 conversion cable (0.5m)	✓	✓	✓	✓	✓	✓	✓	✓	✓	✓	✓	✓	✓	✓	✓	✓	✓	✓	✓	✓	✓
Communication Terminal Block																						
TC-D9	Terminal converter for V8	✓	✓	✓	✓	✓	✓	✓	✓	✓	✓	✓	✓	✓	✓	✓	✓	✓	✓	✓	✓	✓
Card recorder																						
USB-CFREC	USB CF card recorder	✓	✓	✓	✓	✓	✓	✓	✓	✓	✓	✓	✓	✓	✓	✓	✓	✓	✓	✓	✓	✓
Battery																						
V7-BT	Battery for V8, V7, and V606e	✓	✓	✓	✓	✓	✓	✓	✓	✓	✓	✓	✓	✓	✓	✓	✓	✓	✓	✓	✓	✓
Switch guard cover																						
V8H-SWG	Switch guard cover for V808CH																✓	✓				
Wall-hanging clasp																						
V6H-WF	Wall-hanging clasp set (for V808CH/V608CH)																✓	✓				
V6H-WF1	Wall-hanging bracket (wall side) (for V808CH/V608CH)																✓	✓				
V8H-WFV	Fitting for V808CH (VESA-compliant)																✓	✓				
V8H-ST	Stand for V808CH																✓	✓				
Protection sheet																						
V806-GS	V806 protection sheets																	✓	✓	✓	✓	✓
V806-GSN10	V806 protection sheets (Non-glare)																	✓	✓	✓	✓	✓
V608CH-GSN10	V808/V806 protection sheets (Non-glare)																✓	✓				
V808-GS	Surface protection sheets for V808																✓	✓	✓	✓	✓	✓
V808-GSN10	Surface protection sheets for V808 (Non-glare)																✓	✓	✓	✓	✓	✓
V810-GS	Surface protection sheets for V810																	✓	✓	✓	✓	✓
V810-GSN10	Surface protection sheets for V810 (Non-glare)																	✓	✓	✓	✓	✓
V812-GS	Surface protection sheets for V812																	✓	✓			
V812-GSN10	Surface protection sheets for V812 (Non-glare)																	✓	✓			
V715-GS	Surface protection sheets for V815/V715																	✓	✓			
V715-GSN10	Surface protection sheets for V815/V715(Non-glare)																	✓	✓			
Backlight																						
V808-FL ^{*)}	Backlight for V808C series																			✓	✓	
V808S-FL ^{*)}	Backlight for V808S series																	✓	✓			
V810-FL ^{*)}	Backlight for V810S/T/C series																	✓	✓	✓	✓	✓
V812-FL ^{*)}	Backlight for V812S series																		✓	✓		
V715-FL ^{*)}	Backlight for V815X/V715 series																	✓	✓			

*1: Optional unit (DUN-10) is required.
 *2: Used both MJ1/MJ2 ports.
 *3: CCFL type (Ver. a to q only).

Manufacturer	Models	Connection form				V8	V9
		1:1	1:n Multi-drop	n:1 Multi-link2	n:1 Multi-link		
Allen-Bradley	PLC-5	✓	✓		✓	✓	
	PLC-5 (Ethernet)	✓	✓		✓	✓	
	ControlLogix / CompactLogix	✓		✓	✓	✓	
	ControlLogix (Ethernet)	✓	✓		✓	✓	
	SLC500	✓		✓	✓	✓	
	SLC500 (Ethernet TCP/IP)	✓	✓		✓	✓	
	NET-ENI (SLC500 Ethernet TCP/IP)	✓	✓		✓	✓	
	NET-ENI (MicroLogix Ethernet TCP/IP)	✓	✓		✓	✓	
	MicroLogix	✓	✓		✓	✓	
	MicroLogix (Ethernet TCP/IP)	✓	✓		✓	✓	
	Micro 800 Controllers	✓		✓	✓	✓	
	Micro 800 Controllers (Ethernet TCP/IP)	✓	✓		✓	✓	
Automationdirect	Direct LOGIC (K-Sequence)	✓		✓	✓	✓	
	Direct LOGIC (Ethernet UDP/IP)	✓	✓		✓	✓	
	Direct LOGIC (MODBUS RTU)	✓	✓		✓	✓	
Azbil	MX series	✓		✓	✓	✓	
Baumüller	BMx-x-PLC	✓	✓		✓	✓	
BECKHOFF	ADS protocol (Ethernet)	✓	✓		✓	✓	
CIMON	BP series	✓		✓	✓	✓	
	CP series	✓		✓	✓	✓	
	S series	✓	✓		✓	✓	
DELTA	S series (Ethernet)	✓	✓		✓	✓	
DELTA	DVP series	✓	✓		✓	✓	
EATON Cutler-Hammer	ELC	✓	✓		✓	✓	
EMERSON	EC10/20/20H (MODBUS RTU)	✓	✓		✓	✓	
FANUC	Power Mate	✓	✓		✓	✓	
Fatek Automation	FACON FB series	✓	✓		✓	✓	
FUFENG	APC Series Controller	✓	✓		✓	✓	
Fuji Electric	MICREX-F series	✓	✓		✓	✓	
	MICREX-F series V4-compatible	✓	✓		✓	✓	
	MICREX-F T-Link	✓			✓	✓	
	MICREX-F T-Link V4-compatible	✓			✓	✓	
	SPB (N mode) & FLEX-PC series	✓	✓		✓	✓	
	SPB (N mode) & FLEX-PC CPU	✓	✓		✓	✓	
	MICREX-SX (T-Link)	✓			✓	✓	
	MICREX-SX (OPCN-1)	✓			✓	✓	
	MICREX-SX (SX bus)	✓			✓	✓	
	MICREX-SX SPH/SPB/SPM/SPE series	✓			✓	✓	
	MICREX-SX SPH/SPB/SPM/SPE CPU	✓			✓	✓	
	MICREX-SX (Ethernet)	✓			✓	✓	
GE Fanuc	90 series	✓	✓		✓	✓	
	90 series (SNP-X)	✓	✓		✓	✓	
	90 series (SNP)	✓	✓		✓	✓	
	90 series (Ethernet TCP/IP)	✓	✓		✓	✓	
	RX3i (Ethernet TCP/IP)	✓	✓		✓	✓	
Hitachi	HIDIC-S10/2alpha.S10mini	✓		✓	✓	✓	
	HIDIC-S10/2alpha.S10mini (Ethernet)	✓	✓		✓	✓	
	HIDIC-S10/4alpha	✓		✓	✓	✓	
	HIDIC-S10V	✓	✓		✓	✓	
	HIDIC-S10V (Ethernet)	✓	✓		✓	✓	
Hitachi Industrial Equipment Systems	HIDIC-H	✓	✓		✓	✓	
	HIDIC-EHV	✓	✓		✓	✓	
	HIDIC-EHV (Ethernet)	✓	✓		✓	✓	
HYUNDAI	Hi5 Robot (MODBUS RTU)	✓	✓		✓	✓	
	Hi4 Robot (MODBUS RTU)	✓	✓		✓	✓	
IDEC	MICRO 3	✓	✓		✓	✓	
	MICRO Smart	✓	✓		✓	✓	
	MICRO Smart pentra	✓	✓		✓	✓	
Jetter	JetControl Series2/3 (Ethernet UDP/IP)	✓	✓		✓	✓	
JTEKT	TOYOPUC	✓	✓		✓	✓	
	TOYOPUC (Ethernet)	✓	✓		✓	✓	
	TOYOPUC (Ethernet PC10 mode)	✓	✓		✓	✓	
	TOYOPUC-Plus	✓	✓		✓	✓	
	TOYOPUC-Plus (Ethernet)	✓	✓		✓	✓	
	KZ series link	✓	✓		✓	✓	
KEYENCE	KZ-A500 CPU	✓	✓		✓	✓	
	KV10/24 CPU	✓	✓		✓	✓	
	KV-700	✓	✓		✓	✓	
	KV-700 (Ethernet TCP/IP)	✓	✓		✓	✓	
	KV-1000	✓	✓		✓	✓	
	KV-1000 (Ethernet TCP/IP)	✓	✓		✓	✓	
	KV-3000/5000	✓	✓		✓	✓	
	KV-3000/5000 (Ethernet TCP/IP)	✓	✓		✓	✓	
KV-7000 (Ethernet TCP/IP)	✓	✓		✓	✓		
KOYO ELECTRONICS	SU/SG	✓	✓		✓	✓	
	SR-T (K protocol)	✓	✓		✓	✓	
	SU/SG (K-Sequence)	✓	✓		✓	✓	
	SU/SG (Modbus RTU)	✓	✓		✓	✓	
LS	MASTER-KxxxS	✓	✓		✓	✓	
	MASTER-KxxxS CNET	✓	✓		✓	✓	
	MASTER-K series (Ethernet)	✓	✓		✓	✓	
	GLOFA CNET	✓	✓		✓	✓	
	GLOFA GM7 CNET	✓	✓		✓	✓	
	GLOFA GM series CPU	✓	✓		✓	✓	
	GLOFA GM series (Ethernet UDP/IP)	✓	✓		✓	✓	
	XGT/XGK series CNET	✓	✓		✓	✓	
	XGT/XGK series CPU	✓	✓		✓	✓	
	XGT/XGK series (Ethernet)	✓	✓		✓	✓	
	XGT/XGI series CNET	✓	✓		✓	✓	
	XGT/XGI series CPU	✓	✓		✓	✓	
XGT/XGI series (Ethernet)	✓	✓		✓	✓		
MITSUBISHI ELECTRIC	A series link	✓	✓		✓	✓	
	A series CPU	✓	✓		✓	✓	
	A series (OPCN-1)	✓	✓		✓	✓	
	QnA series link	✓	✓		✓	✓	
	QnA series CPU	✓	✓		✓	✓	
	QnA series (Ethernet)	✓	✓		✓	✓	
	QnH (Q) series link	✓	✓		✓	✓	
	QnH (Q) series CPU	✓	✓		✓	✓	
	QnU series CPU	✓	✓		✓	✓	
	Q00J/Q0/O1 CPU	✓	✓		✓	✓	
	QnH (Q) series (Ethernet)	✓	✓		✓	✓	
	QnH (Q) series link (multi CPU)	✓	✓		✓	✓	
	QnH (Q) series (multi CPU) (Ethernet)	✓	✓		✓	✓	
	QnH (Q) series CPU (multi CPU)	✓	✓		✓	✓	
	QnH (Q) series (Ethernet ASCII)	✓	✓		✓	✓	
	QnH (Q) series (multi CPU) (Ethernet ASCII)	✓	✓		✓	✓	

Manufacturer	Models	Connection form				V8	V9
		1:1	1:n Multi-drop	n:1 Multi-link2	n:1 Multi-link		
MITSUBISHI ELECTRIC	QnU series (built-in Ethernet)	✓	✓		✓	✓	
	L series link	✓	✓		✓	✓	
	L series (built-in Ethernet)	✓	✓		✓	✓	
	L series CPU	✓	✓		✓	✓	
	A series (CC-LINK)					✓	
	QnA series (CC-LINK)					✓	
	QnH(Q) series (CC-LINK)					✓	
	FX series CPU	✓		✓		✓	
	FX2N/1N series CPU	✓		✓		✓	
	FX1S series CPU	✓		✓		✓	
	FX series link (A protocol)	✓	✓		✓	✓	
	FX3U/3UC/3G series CPU	✓	✓		✓	✓	
	FX3U/3GE series (Ethernet)	✓	✓		✓	✓	
	FX3U/3UC/3G series link (A protocol)	✓	✓		✓	✓	
	FX5U/5UC series	✓	✓		✓	✓	
	FX5U/5UC series (Ethernet)	✓	✓		✓	✓	
	A-Link + Net10					✓	
	Q170MCP (multi CPU)	✓		✓		✓	
	Q170 series (multi CPU) (Ethernet)	✓	✓		✓	✓	
	IQ-R series (Built-in Ethernet)	✓	✓		✓	✓	
	IQ-R series link	✓	✓		✓	✓	
	IQ-R series (Ethernet)	✓	✓		✓	✓	
	MODICON	Modbus RTU	✓	✓		✓	✓
	MOELLER	PS4	✓	✓		✓	✓
	OMRON	SYSMAC C	✓	✓		✓	✓
		SYSMAC C(OPCN-1)	✓	✓		✓	✓
SYSMAC CV		✓	✓		✓	✓	
SYSMAC CS1/CJ1		✓	✓		✓	✓	
SYSMAC CS1/CJ1 DNA		✓	✓		✓	✓	
SYSMAC CS1/CJ1 (Ethernet)		✓	✓		✓	✓	
SYSMAC CS1/CJ1 (Ethernet Auto)		✓	✓		✓	✓	
SYSMAC CS1/CJ1 DNA (Ethernet)		✓	✓		✓	✓	
FP Series (RS232C/422)		✓	✓		✓	✓	
FP Series (TCP/IP)		✓	✓		✓	✓	
Panasonic	FP Series (UDP/IP)	✓	✓		✓	✓	
	FP-X (TCP/IP)	✓	✓		✓	✓	
	FP7 Series (RS232C/422)	✓	✓		✓	✓	
	FP7 Series (Ethernet)	✓	✓		✓	✓	
RS Automation	NX7/NX Plus Series (70P/700P/CCU+)	✓	✓		✓	✓	
	N7/NX Series (70/700/750/CCU)	✓	✓		✓	✓	
	NX700 Series (Ethernet)	✓	✓		✓	✓	
	X8 Series	✓	✓		✓	✓	
SAIA	X8 Series (Ethernet)	✓	✓		✓	✓	
	PCD	✓	✓		✓	✓	
SAMSUNG	PCD S-BUS (Ethernet)	✓	✓		✓	✓	
	SPC series	✓	✓		✓	✓	
SHARP	N_plus	✓	✓		✓	✓	
	SECNET	✓	✓		✓	✓	
	JW series	✓	✓		✓	✓	
	JW100/70H COM port	✓	✓		✓	✓	
SINFONIA TECHNOLOGY	JW20 COM port	✓	✓		✓	✓	
	JW series (Ethernet)	✓	✓		✓	✓	
	JW300 series	✓	✓		✓	✓	
	JW311/312/321/322 series (Ethernet)	✓	✓		✓	✓	
Siemens	JW331/332/341/342/352/362 series (Ethernet)	✓	✓		✓	✓	
	SELMART	✓	✓		✓	✓	
	S5 PG port	✓	✓		✓	✓	
	S7	✓	✓		✓	✓	
	S7-200 PPI	✓	✓		✓	✓	
	S7-200 (Ethernet ISOTCP)	✓	✓		✓	✓	
	S7-300/400 MPI	✓	✓		✓	✓	
	S7-300/400 (Ethernet ISOTCP)	✓	✓		✓	✓	
	S7-300/400 (Ethernet TCP/IP PG protocol)	✓	✓		✓	✓	
	S7-1200/1500 (Ethernet ISOTCP)	✓	✓		✓	✓	
	S7 PROFIBUS-DP	✓	✓		✓	✓	
	Ti500/505	✓	✓		✓	✓	
Ti500/505 V4 Compatible	✓	✓		✓	✓		
TECO	TP03 (MODBUS RTU)	✓	✓		✓	✓	
TELEMECANIQUE	TSX Micro	✓	✓		✓	✓	
TOSHIBA	T series /V series (T compatible)	✓	✓		✓	✓	
	T series /V series (T compatible) (Ethernet UDP/IP)	✓	✓		✓	✓	
TOSHIBA MACHINE	EX series	✓	✓		✓	✓	
	nv series (Ethernet UDP/IP)	✓	✓		✓	✓	
TOYO DENKI	TC200	✓	✓		✓	✓	
	μGPCsx(OPCN-1)	✓	✓		✓	✓	
	μGPCsx series	✓	✓		✓	✓	
	μGPCsx CPU	✓	✓		✓	✓	
TURCK	μGPCsx series (Ethernet)	✓	✓		✓	✓	
	BL Series Distributed I/O (MODBUS TCP/IP)	✓	✓		✓	✓	
Ultra Instruments	UIC CPU (MODBUS ASCII)	✓	✓		✓	✓	
UNITRONICS	M90/M91/Vision Series (ASCII)	✓	✓		✓	✓	
VIGOR	Vision Series (ASCII Ethernet TCP/IP)	✓	✓		✓	✓	
WAGO	M series	✓	✓		✓	✓	
	750 series (MODBUS RTU)	✓	✓		✓	✓	
XINJE	750 series (MODBUS Ethernet)	✓	✓		✓	✓	
	XC Series (MODBUS RTU)	✓	✓		✓	✓	
Yaskawa Electric	MEMOBUS	✓	✓		✓	✓	
	CP9200SH/MP900	✓	✓		✓	✓	
	MP2300 (MODBUS TCP/IP)	✓	✓		✓	✓	
	CP/MP EXPANSION MEMOBUS (UDP/IP)	✓	✓		✓	✓	
	MP2000 series	✓	✓		✓	✓	
	MP2000 series (UDP/IP)	✓	✓		✓	✓	
	MP3000 Series EXPANSION MEMOBUS (Ethernet)	✓	✓		✓	✓	
	FA-M3	✓	✓		✓	✓	
	FA-M3R	✓	✓		✓	✓	
	FA-M3/FA-M3R (Ethernet UDP/IP)	✓	✓		✓	✓	
FA-M3/FA-M3R (Ethernet UDP/IP ASCII)	✓	✓		✓	✓		
Yokogawa Electric	FA-M3/FA-M3R (Ethernet TCP/IP)	✓	✓		✓	✓	
	FA-M3/FA-M3R (Ethernet TCP/IP ASCII)	✓	✓		✓	✓	
	FA-M3V	✓	✓		✓	✓	
	FA-M3V (Ethernet)	✓	✓		✓	✓	
Others	FA-M3V (Ethernet ASCII)	✓	✓		✓	✓	
	Universal serial	✓	✓		✓	✓	
	MODBUS RTU	✓	✓		✓	✓	
	MODBUS RTU EXT Format	✓	✓		✓	✓	
	MODBUS TCP/IP (Ethernet)	✓	✓		✓	✓	
	MODBUS TCP/IP (Ethernet) Sub Station	✓	✓		✓	✓	
	MODBUS TCP/IP (Ethernet) EXT Format	✓	✓		✓	✓	
	MODBUS ASCII	✓	✓		✓	✓	

Manufacturer	Models	Connection form				V8	V9
		1:1	1:n Multi-drop	n:1 Multi-link2	n:1 Multi-link		
Agilent	4263 Series	✓		✓		✓	✓
	SDC10	✓	✓	✓	✓	✓	✓
	SDC15	✓	✓	✓	✓	✓	✓
	SDC20	✓	✓	✓	✓	✓	✓
	SDC21	✓	✓	✓	✓	✓	✓
	SDC25/26	✓	✓	✓	✓	✓	✓
	SDC30/31	✓	✓	✓	✓	✓	✓
	SDC35/36	✓	✓	✓	✓	✓	✓
	SDC40A	✓	✓	✓	✓	✓	✓
	SDC40G	✓	✓	✓	✓	✓	✓
	SDC45/46	✓	✓	✓	✓	✓	✓
	DMC10	✓	✓	✓	✓	✓	✓
	DMC50 (COM)	✓	✓	✓	✓	✓	✓
	AHC2001	✓	✓	✓	✓	✓	✓
	AHC2001+DCP31/32	✓	✓	✓	✓	✓	✓
	DCP31/32	✓	✓	✓	✓	✓	✓
	NX (CPL)	✓	✓	✓	✓	✓	✓
	NX (MODBUS RTU)	✓	✓	✓	✓	✓	✓
	NX (MODBUS TCP/IP)	✓	✓	✓	✓	✓	✓
Banner	Presence PLUS (Ethernet/IP (TCP/IP))	✓	✓	✓	✓	✓	✓
Bosch Rexroth	IndraDrive	✓	✓	✓	✓	✓	✓
	LT400 Series (MODBUS RTU)	✓	✓	✓	✓	✓	✓
	DP1000	✓	✓	✓	✓	✓	✓
	DB1000B (MODBUS RTU)	✓	✓	✓	✓	✓	✓
	KR2000 (MODBUS RTU)	✓	✓	✓	✓	✓	✓
	LT230 (MODBUS RTU)	✓	✓	✓	✓	✓	✓
	LT300 (MODBUS RTU)	✓	✓	✓	✓	✓	✓
	LT830 (MODBUS RTU)	✓	✓	✓	✓	✓	✓
DELTA TAU DATA SYSTEMS	PMAC	✓	✓	✓	✓	✓	✓
	PMAC (Ethernet TCP/IP)	✓	✓	✓	✓	✓	✓
	PYX (MODBUS RTU)	✓	✓	✓	✓	✓	✓
	PXR (MODBUS RTU)	✓	✓	✓	✓	✓	✓
	PXF (MODBUS RTU)	✓	✓	✓	✓	✓	✓
	PXG (MODBUS RTU)	✓	✓	✓	✓	✓	✓
	PXH (MODBUS RTU)	✓	✓	✓	✓	✓	✓
	PUM (MODBUS RTU)	✓	✓	✓	✓	✓	✓
	F-MPC04P (Loader)	✓	✓	✓	✓	✓	✓
	F-MPC series /FePSU	✓	✓	✓	✓	✓	✓
	FVR-E11S	✓	✓	✓	✓	✓	✓
	FVR-E11S (MODBUS RTU)	✓	✓	✓	✓	✓	✓
	FVR-C11S (MODBUS RTU)	✓	✓	✓	✓	✓	✓
	FRENIC-Ace (MODBUS RTU)	✓	✓	✓	✓	✓	✓
	FRENIC5000 G11S/P11S	✓	✓	✓	✓	✓	✓
	FRENIC5000 G11S/P11S (MODBUS RTU)	✓	✓	✓	✓	✓	✓
	FRENIC5000 VG7S (MODBUS RTU)	✓	✓	✓	✓	✓	✓
	FRENIC-HVAC/AQUA (MODBUS RTU)	✓	✓	✓	✓	✓	✓
	FRENIC-Mini (MODBUS RTU)	✓	✓	✓	✓	✓	✓
	FRENIC-Eco (MODBUS RTU)	✓	✓	✓	✓	✓	✓
	FRENIC-Multi (MODBUS RTU)	✓	✓	✓	✓	✓	✓
	FRENIC-MEGA (MODBUS RTU)	✓	✓	✓	✓	✓	✓
	FRENIC-MEGA SERVO(MODBUS RTU)	✓	✓	✓	✓	✓	✓
	FRENIC-VG1 (MODBUS RTU)	✓	✓	✓	✓	✓	✓
	HFR-C9K	✓	✓	✓	✓	✓	✓
	HFR-C11K	✓	✓	✓	✓	✓	✓
	HFR-K1K	✓	✓	✓	✓	✓	✓
	PPMC (MODBUS RTU)	✓	✓	✓	✓	✓	✓
	FALDIC-alpha series	✓	✓	✓	✓	✓	✓
	FALDIC-W series	✓	✓	✓	✓	✓	✓
	PH series	✓	✓	✓	✓	✓	✓
	PHR (MODBUS RTU)	✓	✓	✓	✓	✓	✓
	WA5000	✓	✓	✓	✓	✓	✓
	APR-N (MODBUS RTU)	✓	✓	✓	✓	✓	✓
	ALPHA5 (MODBUS RTU)	✓	✓	✓	✓	✓	✓
	ALPHA5 Smart (MODBUS RTU)	✓	✓	✓	✓	✓	✓
	WE1MA (Ver. A)(MODBUS RTU)	✓	✓	✓	✓	✓	✓
	WE1MA (Ver. B)(MODBUS RTU)	✓	✓	✓	✓	✓	✓
	WSZ series	✓	✓	✓	✓	✓	✓
	WSZ series (Ethernet)	✓	✓	✓	✓	✓	✓
Gammflux	TTC2100	✓	✓	✓	✓	✓	✓
Hitachi Industrial Equipment Systems	SJ300 series	✓	✓	✓	✓	✓	✓
	SJ700 series	✓	✓	✓	✓	✓	✓
	X-SEL controller	✓	✓	✓	✓	✓	✓
	ROBO CYLINDER (RCP2/ERC)	✓	✓	✓	✓	✓	✓
	ROBO CYLINDER (RCS/E-CON)	✓	✓	✓	✓	✓	✓
	PCON/ACON/SCON (MODBUS RTU)	✓	✓	✓	✓	✓	✓
KOGANEI	IBFL-TC	✓	✓	✓	✓	✓	✓
Lenze	ServoDrive9400(Ethernet TCP/IP)	✓	✓	✓	✓	✓	✓
	FR-*500	✓	✓	✓	✓	✓	✓
	FR-V500	✓	✓	✓	✓	✓	✓
	MR-J2S-*A	✓	✓	✓	✓	✓	✓
	MR-J3-*A	✓	✓	✓	✓	✓	✓
	MR-J3-*T	✓	✓	✓	✓	✓	✓
	FR-E700	✓	✓	✓	✓	✓	✓
MOOG	J124-04x Series	✓	✓	✓	✓	✓	✓

Manufacturer	Models	Connection form				V8	V9
		1:1	1:n Multi-drop	n:1 Multi-link2	n:1 Multi-link		
M-SYSTEM	R1M series (MODBUS RTU)	✓	✓	✓	✓	✓	✓
	E5AK	✓	✓	✓	✓	✓	✓
	E5AK-T	✓	✓	✓	✓	✓	✓
	E5AN/E5EN/E5CN/E5GN	✓	✓	✓	✓	✓	✓
	E5AR/E5ER	✓	✓	✓	✓	✓	✓
	E5CK	✓	✓	✓	✓	✓	✓
	E5CK-T	✓	✓	✓	✓	✓	✓
	E5CN-HT	✓	✓	✓	✓	✓	✓
	E5EK	✓	✓	✓	✓	✓	✓
	E5ZD	✓	✓	✓	✓	✓	✓
	E5ZE	✓	✓	✓	✓	✓	✓
	E5ZN	✓	✓	✓	✓	✓	✓
	V600/620/680	✓	✓	✓	✓	✓	✓
	KM20	✓	✓	✓	✓	✓	✓
	KM100	✓	✓	✓	✓	✓	✓
	V680S (Ethernet TCP/IP)	✓	✓	✓	✓	✓	✓
Orientalmotor	High-efficiency AR series (MODBUS RTU)	✓	✓	✓	✓	✓	✓
	CRK series (MODBUS RTU)	✓	✓	✓	✓	✓	✓
Panasonic	MINAS A4 series	✓	✓	✓	✓	✓	✓
	LP-400	✓	✓	✓	✓	✓	✓
	KW Series	✓	✓	✓	✓	✓	✓
	SR-Mini (MODBUS RTU)	✓	✓	✓	✓	✓	✓
	CB100/CB400/CB500/CB700/CB900 (MODBUS RTU)	✓	✓	✓	✓	✓	✓
	SR-Mini (Standard Protocol)	✓	✓	✓	✓	✓	✓
	REX-F400/F700/F900 (Standard Protocol)	✓	✓	✓	✓	✓	✓
	SRV (MODBUS RTU)	✓	✓	✓	✓	✓	✓
	MA900/MA901 (MODBUS RTU)	✓	✓	✓	✓	✓	✓
	SRZ (MODBUS RTU)	✓	✓	✓	✓	✓	✓
	FB100/FB400/FB900 (MODBUS RTU)	✓	✓	✓	✓	✓	✓
	CSD5 (MODBUS RTU)	✓	✓	✓	✓	✓	✓
	Moscon-F50 (MODBUS RTU)	✓	✓	✓	✓	✓	✓
RS Automation	Cuty Axis	✓	✓	✓	✓	✓	✓
SanRex	DC AUTO (HKD type)	✓	✓	✓	✓	✓	✓
SHARP	DS-30D	✓	✓	✓	✓	✓	✓
	DS-32D	✓	✓	✓	✓	✓	✓
SHIMADEN	SHIMADEN standard protocol	✓	✓	✓	✓	✓	✓
	C Series	✓	✓	✓	✓	✓	✓
	FC Series	✓	✓	✓	✓	✓	✓
	GC Series	✓	✓	✓	✓	✓	✓
	DCL-33A	✓	✓	✓	✓	✓	✓
	JCx-300 Series	✓	✓	✓	✓	✓	✓
	PC-900	✓	✓	✓	✓	✓	✓
	PCD-33A	✓	✓	✓	✓	✓	✓
	ACS-13A	✓	✓	✓	✓	✓	✓
	ACD/ACR Series	✓	✓	✓	✓	✓	✓
	WCL-13A	✓	✓	✓	✓	✓	✓
SUS	XA-A*	✓	✓	✓	✓	✓	✓
	TTM-000	✓	✓	✓	✓	✓	✓
	TTM-00BT	✓	✓	✓	✓	✓	✓
	TTM-200 (MODBUS RTU)	✓	✓	✓	✓	✓	✓
TOKYO CHOKOKU PRODUCTS	MB3315/1010	✓	✓	✓	✓	✓	✓
	VF-S7	✓	✓	✓	✓	✓	✓
	VF-S9	✓	✓	✓	✓	✓	✓
	VF-S11	✓	✓	✓	✓	✓	✓
	VF-S15	✓	✓	✓	✓	✓	✓
	VF-A7	✓	✓	✓	✓	✓	✓
	VF-AS1	✓	✓	✓	✓	✓	✓
	VF-P7	✓	✓	✓	✓	✓	✓
	VF-PS1	✓	✓	✓	✓	✓	✓
	VF-FS1	✓	✓	✓	✓	✓	✓
	VF-MB1	✓	✓	✓	✓	✓	✓
	VF-nC1	✓	✓	✓	✓	✓	✓
	VF-nC3	✓	✓	✓	✓	✓	✓
TOSHIBA MACHINE	VELCONIC series	✓	✓	✓	✓	✓	✓
ULVAC	G-TRAN series	✓	✓	✓	✓	✓	✓
	F340A	✓	✓	✓	✓	✓	✓
	F371	✓	✓	✓	✓	✓	✓
	F800	✓	✓	✓	✓	✓	✓
	F720A	✓	✓	✓	✓	✓	✓
	F805A	✓	✓	✓	✓	✓	✓
YAMAHA	RCX142	✓	✓	✓	✓	✓	✓
	UT100	✓	✓	✓	✓	✓	✓
	UT750	✓	✓	✓	✓	✓	✓
	UT550	✓	✓	✓	✓	✓	✓
	UT520	✓	✓	✓	✓	✓	✓
	UT350	✓	✓	✓	✓	✓	✓
	UT320	✓	✓	✓	✓	✓	✓
	UT2400/2800	✓	✓	✓	✓	✓	✓
	UT450	✓	✓	✓	✓	✓	✓
	UT32A/35A(MODBUS RTU)	✓	✓	✓	✓	✓	✓
	UT52A/55A(MODBUS RTU)	✓	✓	✓	✓	✓	✓
	UT75A(MODBUS RTU)	✓	✓	✓	✓	✓	✓
	μR10000/20000 (Ethernet TCP/IP)	✓	✓	✓	✓	✓	✓
	MODBUS RTU	✓	✓	✓	✓	✓	✓
	MODBUS TCP/IP (Ethernet)	✓	✓	✓	✓	✓	✓
Others		✓	✓	✓	✓	✓	✓

Worldwide service network for trouble-free

Tel

FAX

Tel +81-76-274-2144 Fax +81-76-274-5136

E-mail

✉ sales@hakko-elec.co.jp

WEB

<http://www.monitouch.com/>



Global Sales Network

Our distributors are ready to support your worldwide business.

<http://monitouch.fujielectric.com/site/distributors-e/distributors-oversea-01.html>



operations

To the purchasers of Hakko Electronics products:

The warranty of this product is as follows, unless there are special instructions that state otherwise in the quote, contract, catalog, or specifications at the time of the quote or order.

The purpose or area of use may be limited, and a routine checkup may be required depending on the product. Please contact the distributor from which you purchased the product, or Hakko Electronics for further information.

Please conduct inspection of the product promptly upon purchase or delivery. Also, please give sufficient consideration to management and maintenance of the product prior to accepting it.

1 Period and Coverage of the Warranty

1-1 Period

- (1) The period of the warranty is effective until twenty-four (24) months from the date of manufacture printed on the plate.
- (2) The above period may not be applicable if the particular environment, conditions or frequency of use affects the lifetime of the product.
- (3) The warranty for the parts repaired by Hakko Electronics' service department is effective for six (6) months from the date of repair.

1-2 Coverage

- (1) If malfunction occurs during the period of warranty due to negligence on the part of Hakko Electronics, the malfunctioning parts are exchanged or repaired free of charge at the point of purchase or delivery. However, the warranty does not apply to the following cases:
 - 1) The malfunction occurs due to inappropriate conditions, environment, handling or usage that is not specified in the catalog, instruction book or users' manual.
 - 2) The malfunction is caused by factors that do not originate in the purchased or delivered product.
 - 3) The malfunction is caused by another device or software design that does not originate in a Hakko Electronics product.
 - 4) The malfunction occurs due to an alteration or repair that was not performed by Hakko Electronics.
 - 5) The malfunction occurs because the expendable parts listed in the instruction book or catalog were not maintained or replaced in an appropriate manner.
 - 6) The malfunction occurs due to factors that were not foreseeable by the practical application of science and technology at the time of purchase or delivery.
 - 7) The malfunction occurs because the product is used for a purpose other than that for which it is intended.
 - 8) The malfunction occurs due to a disaster or natural disaster that Hakko Electronics is not responsible for.
- (2) The warranty is only applicable to the single purchased and delivered product.
- (3) The warranty is only valid for the conditions stated in (1) above. Any damage induced by the malfunction of the purchased or delivered product, including damage or loss to a device or machine and passive damage, is not covered by the warranty.

1-3 Malfunction Diagnosis

The initial diagnosis of malfunction is to be made by the purchaser. The diagnosis can be conducted by Hakko Electronics or its delegated service provider with due charge upon the request of the purchaser. The charge is to be paid by the purchaser at the rate stipulated in the rate schedule of Hakko Electronics.

2 Liability for Opportunity Loss

Regardless of the time of occurrence, Hakko Electronics is not liable for damage caused by factors that Hakko Electronics is not responsible for, opportunity loss on the part of the purchaser caused by the malfunction of a Hakko Electronics product, passive damage, damage due to a special situation regardless of whether it was foreseeable or not, or secondary damage, accident compensation, damage to products that were not manufactured by Hakko Electronics, or compensation towards other operations.

3 Period for Repair and Provision of Spare Parts after Production is Discontinued (Maintenance Period)

Discontinued models (products) can be repaired for seven (7) years from the date of discontinuation. Also, most spare parts used for repair are provided for seven (7) years from the date of discontinuation. However, some electric parts may not be available due to their short life cycle. In this case, it may be difficult to repair or provide the parts during the seven-year period. Please contact Hakko Electronics or its service providers for further information.

4 Delivery

Standard products that do not entail application setting or adjustment are regarded as received by the purchaser upon delivery. Hakko Electronics is not responsible for local adjustments and test runs.

5 Service

The price of the delivered or purchased products does not include the service fee for the technician. Please contact Hakko Electronics or its service providers for further information.

6 Scope of Application

The above contents shall be assumed to apply to transactions and product use in the country where a Hakko Electronics product is purchased. Please consult your local supplier or Hakko Electronics for details.