

UNIK 5900 SIL

Flameproof/Explosion Proof Pressure Sensing Platform, SIL Certified Version

The UNIK 5900 is a compact and rugged version of the high performance UNIK 5000 pressure sensing platform with SIL certification. It also offers intrinsically safe, flameproof/explosion proof or dust ignition protection by enclosure capability as required. It provides a cost-effective alternative to pressure gauges and switches in process and oil and gas industry applications.

High Quality

With over 40 years of pressure measurement experience, our field-proven Druck technology is at the heart of the new platform, resulting in a range of high quality, high stability pressure sensors.

Bespoke as Standard

Custom-built from standard components, manufacturing sensors to your requirement is quick and simple; each UNIK 5900 is a “bespoke” pressure sensing solution, but with the short lead times and competitive pricing you would expect from standard products.

Expertise

We have the people and the knowledge to support your needs for accurate and reliable product performance; our team of experts can help you make the right sensor selection, guiding you and providing the help and tools you need. It is important that you ensure that the sensor materials and performance selected are suitable for your application.



Features

- Ranges from 2 to 700 bar (30 to 10000 psi)
- Non-linearity, hysteresis and repeatability to $\pm 0.04\%$ Full Scale (FS) Best Straight Line (BSL)
- Stainless steel construction
- Integrated terminal compartment with long or short body
- Frequency response to 3.5 kHz
- Hazardous area certifications
- SIL certification. For non-SIL certified products, please refer to our standard UNIK 5900 datasheet, 920-582

UNIK 5900 SIL Conformity Specifications

Operating Pressure Ranges

Gauge Ranges

Any zero based range from 2 to 50 bar
(30 to 725 psi)

Sealed Gauge Ranges

Any zero based range from 10 to 700 bar
(146 to 10000 psi)

Absolute Ranges

Any zero based range from 2 to 700 bar
(30 to 10000 psi)

Non-Zero Based Ranges

Non-zero based ranges are available. Please contact Baker Hughes to discuss your requirements.

Over Pressure

1.5 × FS

Containment Pressure

Ranges up to 50 bar (725 psi) gauge:
6 × FS (200 bar (2900 psi) max)

Ranges up to 50 bar (725 psi) absolute:
200 bar (2900 psi) maximum

Ranges above 50 bar (725 psi) absolute:
1200 bar (17400 psi) maximum

Electrical Specifications

Supply and Output Voltage

Supply : 7 to 28 Vdc (32 V maximum for non-hazardous area operation)

Output : 4 to 20 mA

Supply Sensitivity

±0.005% FS/V

Power-up Time

10 ms

Insulation Resistance

>100 MΩ at 500 Vdc (approval option H0 only)

Isolation

500 Vac: Leakage ≤5 mA (approval options other than H0)

Performance Specifications

There are three grades of performance specification: Industrial, Improved and Premium

Accuracy

Combined effects of non-linearity, hysteresis and repeatability:

Industrial: ±0.2% FS BSL

Improved: ±0.1% FS BSL

Premium: ±0.04% FS BSL

Temperature Effects

Four compensated temperature ranges can be chosen:

Compensated Temperature Range	Industrial (%FS TEB)	Improved and Premium (%FS TEB)
-40 to +125 °C	±2.25	±1.50
-40 to +80 °C	±2.25	±1.50
-20 to +80 °C	±1.50	±1.00
-10 to +50 °C	±0.75	±0.50

Zero and Span Setting

Zero and span potentiometers allow adjustment range of at least ±5% FS.

Factory set to:

Industrial: ±0.5% FS

Improved: ±0.2% FS

Premium: ±0.2% FS

Note: Adjusting zero or span may invalidate SIL compliance - refer to safety manual.

Long Term Stability

±0.05% FS/year typical (±0.1% FS/year maximum)

Safety Accuracy

Safety accuracy includes non-linearity, hysteresis and repeatability, thermal error, zero/span setting accuracy and lifetime drift.

Compensated Temperature Range	Industrial (%FS)	Improved and Premium (%FS)
-40 to +125 °C	4.45	3.00
-40 to +80 °C	4.45	3.00
-20 to +80 °C	3.70	2.50
-10 to +50 °C	2.95	2.00

Fault State Output: ≤3.6mA or ≥ 21mA

Physical Specifications

Environmental Protection

See the Electrical Connector section

Operating Temperature Range

See the Electrical Connector section

Pressure Media

0 - 200 bar: fluids compatible with stainless steel 316L and Hastelloy C276
201 - 500 bar: liquids and group 2 gases compatible with stainless steel 316L
501 - 700 bar: group 2 liquids and group 2 gases compatible with stainless steel 316L

Enclosure Materials

Stainless steel (body), Viton (O-ring), PTFE (vent filter)

Pressure Connector

See Ordering Information for available options

Electrical Connector

Option Code	Description	Max Operating Temp Range***		IP Rating	Zero/ Span Adjust
		°C	°F		
B	M20 female conduit with terminal compartment	-40 to +100	-40 to +212	66/67*	Y
J**	½ NPT female conduit with terminal compartment	-40 to +100	-40 to +212	66/67*	Y

*Designed to be enclosure Type 4X, IP66 and IP67 when properly installed with conduit fitting.

**Option J is supplied with an M20 to ½" NPT female conduit thread adaptor.

***Note: hazardous area approved versions may be restricted to a reduced maximum operating temperature range – see Hazardous Area Approvals.

Electrical Connections

Label	Function
I/P+	+ve Supply
O/P+	-
O/P-	-
I/P-	-ve Supply

Certification

CE Conformity

- Pressure Equipment Directive 2014/68/EU – Sound Engineering Practice
 - ATEX Directive 2014/34/EU (Optional)
 - EMC Directive 2014/30/EU
 - BS EN 61000-6-1: 2007
 - BS EN 61000-6-2: 2005
 - BS EN 61000-6-3: 2007+A1:2011
 - BS EN 61000-6-4: 2007+A1:2011
 - BS EN 61326-1: 2013
 - BS EN 61326-2-3: 2013
 - RoHS Directive 2011/65/EU
- Susceptibility – Light Industrial
Susceptibility – Heavy Industrial
Emissions – Light Industrial
Emissions – Heavy Industrial
Electrical Equipment for Measurement, Control and Laboratory Use
Particular Requirements for Pressure Transducers

SIL Conformity

- Certificate number: 2103.2494
- Issued by: Method Functional Safety
- Assessed Standard: SIL2 IEC 61508:2010 (Parts 1 & 2)
- Basis of Certification:
Report 2103.03 v1 – Functional Safety Management, Hardware Requirements, Hardware Reliability
- Safety Manual I24M4659

Hazardous Area Approvals (Optional)

ATEX/IECEx Flameproof or Dust Ignition Protection by Enclosure

Ex d IIC T* Gb
Ex tb IIIC T*°C Db
T6/T85°C (-40°C ≤ Ta ≤ +70°C)
T5/T100°C (-40°C ≤ Ta ≤ +80°C)
T4/T135°C (-40°C ≤ Ta ≤ +100°C)
Per certificates Baseefa I2ATEX0074X & IECEx BAS I2.0046X

ATEX/IECEx Intrinsic Safety

Ex ia IIC T5 Ga (-40°C ≤ Ta ≤ +80°C)
Ex ia I Ma (-40°C ≤ Ta ≤ +80°C)
Per certificates Baseefa I0ATEX0204X & IECEx BAS I0.0103X

FM Approvals (Canada & United States) Explosionproof/Flameproof and/or Dust Ignition Proof by Enclosure

XP CL I DIV 1 GP ABCD T*
CL I ZN 1 AEx/Ex d IIC T*
CL II, III DIV 1 GP EFG T*/T*°C
ZN 21 AEx tb IIIC T*°C
T6/T85°C (-40°C ≤ Ta ≤ +70°C)
T5/T100°C (-40°C ≤ Ta ≤ +80°C)
T4/T135°C (-40°C ≤ Ta ≤ +100°C)
Single Seal (-40°C - +125°C)
Per FM Approvals certificates FM16US0420X (United States) and FM16CA0193X (Canada)

Note: Model 59B2, using a metric electrical conduit thread, is not permitted for installation in 'Divisions' classified installations in Canada.

Note: Model 59J2, using a metric electrical conduit thread and supplied with a metric to NPT thread adaptor, must be installed with the adaptor fitted.

Ordering Information

(1) Select model number

Main Product Variant

PTX 4-20 mA Pressure Transmitter

Product Series

5 UNIK 5000

Diameter and Material

9 60mm Stainless Steel 316L Female Conduit with Terminal Compartment

Electrical Connector

B M20 Female Conduit with Terminal Compartment

J 1/2" NPT Female Conduit with Terminal Compartment

Electronics Option

2 4 to 20 mA 2-wire (PTX)

Compensated Temperature Range

TA -10 to +50 °C (14 to +122 °F)

TB -20 to +80 °C (-4 to +176 °F)

TC -40 to +80 °C (-40 to +176 °F)

TD -40 to +125 °C (-40 to +257 °F)

Accuracy

A1 Industrial

A2 Improved

A3 Premium

Calibration

CC Full Thermal

Hazardous Area Approval

H0 None

H1 IECEx/ATEX Intrinsically Safe 'ia' Group IIC

H2 IECEx/ATEX Intrinsically Safe 'ia' Group I

H3 IECEx/ATEX Protected by Enclosure Group IIIC

H4 IECEx/ATEX Flameproof Group IIC

H7 FM (C & US) Dust Ignition Proof, Groups IIIC/EFG

H8 FM (C & US) Flameproof/Explosion Proof, Groups IIC/ABCD

HA IECEx/ATEX Intrinsically Safe 'ia' Groups I/IIC [H1 + H2]

HT IECEx/ATEX/FM (C & US) Flameproof/Explosion Proof Groups IIC/ABCD [H4 + H8]

Pressure Connector

PM G1/2 Female

PN G1/2 Male

PP 1/2 NPT Female

PR 1/2 NPT Male

RM G1/2 Female Long Version

RN G1/2 Male Long Version

RP 1/2 NPT Female Long Version

RR 1/2 NPT Male Long Version

125M0202 SIL Certification

PTX 5 9 J 2 - TA - A1 - CC - HI - PN - 125M0202 Typical Model Number

(2) State pressure range and units: e.g., 0 to 10 bar, -5 to + 100 psi

Unit options are:

Symbol	Description	Symbol	Description
bar	bar	mH ₂ O	metres water
mbar	millibar	inH ₂ O	inches water
psi	pounds/sq. inch	ftH ₂ O	feet water
Pa	Pascal	mmHg	mm mercury
hPa	hectoPascal	inHg	inches mercury
kPa	kiloPascal	kgf/cm ²	kg force/sq. cm
MPa	MegaPascal	atm	atmosphere
mmH ₂ O	mm water	Torr	torr
cmH ₂ O	cm water		

(3) State pressure reference e.g., gauge

Reference options are:

- gauge
- absolute
- sealed gauge

Typical order examples

PTX59J2-TA-A1-CC-HI-PN-125M0202, 0 to 5 bar absolute

PTX59B2-TB-A2-CC-H0-PR-125M0202, 0 to 10 MPa gauge

Mechanical Drawings

**UNIK 5900 Bracket
Compatible Outline Details**
Available for all pressure
ranges and either G1/2 or
1/2 NPT pressure connectors
in Male or Female.

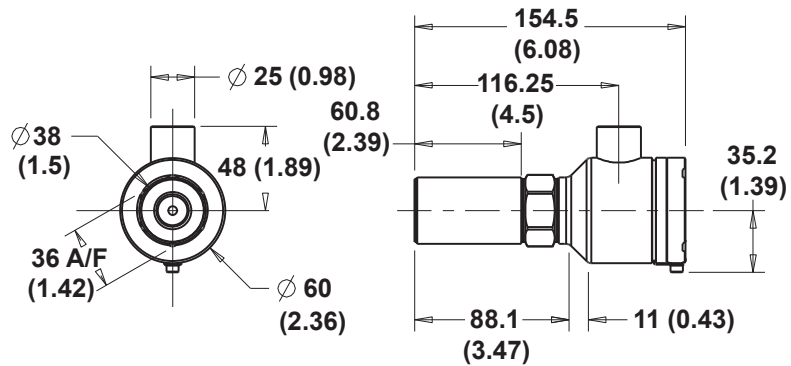

**1/2 NPT Conduit
Adapter**
Use to adapt the
standard M20 x 1.5
conduit connection.

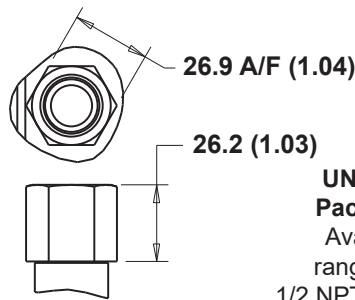

**UNIK 5900 Miniaturized
Package Outline Details**
Available for all pressure
ranges and either G1/2 or
1/2 NPT pressure connectors
in Male or Female

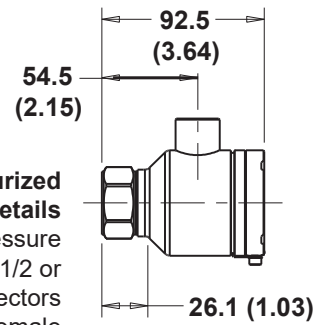

Note: All dimensions in mm (inches)



Per avere più informazioni

EP srl
41124 Modena
Via S. Faustino, 155/P
Tel. +39 059 35 76 00

www.epsas.it
www.ep-ma.it
ep.ma@epsas.it

Druck.com

Copyright 2020. Baker Hughes Company. This material contains one or more registered trademark of Baker Hughes Company and its subsidiaries in one or more countries. All third-party product and company names are trademarks of their respective holders.

920-689A

Baker Hughes 